

AVANT LCR 250

aluminum extruded centre speaker | owners manual

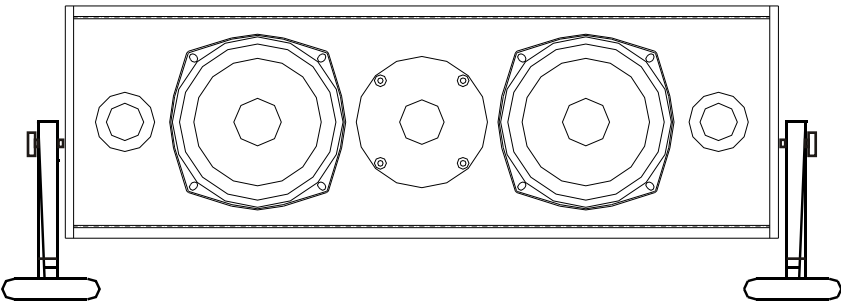

SONODYNE[®]
www.sonodyne.com

INTRODUCTION

Congratulations on your choice of Avant LCR 250 aluminum extruded speaker. In today's digital cinema formats you are now ensured that all dialogues will come through loud and clear ... in fact, don't be surprised if you sense that the actors are right there in the room with you! With music too, the LCR 250 excels, producing vocals and lead instruments with great gusto. To help you get listening quickly, we have included here our thoughts on the setup and listening processes. And after you are all set up, do drop us a line through www.sonodyne.com.

UNPACKING

Your carton contains 1 Avant LCR 250 center speaker. A separate box contains the table mount brackets.

We suggest that the LCR 250 be "broken in", that is played for some time, so that it may quickly start performing at its best! If you do not want to do this when you are at home set your source unit, ie., CD player on "repeat entire disc" mode. Then, allow the loudspeaker to play at moderate volume level for a 6 - 8 hrs.

NOTE : Please retain all packing materials in case you need to transport the Avant LCR 250

The Avant LCR 250 is equipped with gold-plated binding post terminals, where red indicates +ve and black indicates -ve. The following information should assist in choosing the correct cable if extra cable is required:

Cable run	Cable gauge
< 3 m	14/36 (14 strands of 36 SWG)
3-6 m	23/36
> 6 m	48/36

Please proceed with the connection in the following fashion:

- Turn off the amplifier.
- Gently pull off the insulation on the cable ends (which have been pre-cut at the factory)
- Twist the wires.
- Turn the gold plated binding posts counter-clockwise until the twisted wires can be easily inserted into the holes.
- Turn the binding posts clockwise to secure the cables in the terminals.
- Ensure the connection is a tight fit.

NOTE:

A Verify that the wires from the +ve and -ve cables do not touch each other, as a short-circuit could damage the amplifier's output stage.

B. Verify that the loudspeaker is in proper phase:

The + (red) terminal on the loudspeaker is connected to the + (red) terminal on the amplifier.

The - (black) terminal on the loudspeaker is connected to the - (black) terminal on the amplifier.

• acoustics of the listening room •

The acoustical makeup of your listening room is key in determining how good (or bad) is the sound that reaches your ear. The contents of a room (carpets, curtains, furniture etc.), its shape, and the material of which the boundaries are made, make or break your sound. The idea is to have a listening area where the absorptions and reflections are calibrated to attain, as far as possible, a neutral environment. While there are no 'quick fix' formulae to convert a room to an 'ideal listening room', here are some things that you might try to attain optimal performance.

In your listening room, clap your hands, snap your fingers, and jingle a ring of keys.

If the resulting sound is unintelligible (muffled), and resonating, your room is inclined toward being reflective. In this event, you might want to: Hang up curtains/ Lay a carpet or rug / Introduce book cases/other racks. In the event that the resulting sound is too damped your room is inclined toward being absorptive. You might want to remove some of the absorptive material (like those given above).

SPEAKER PLACEMENT

The Avant LCR 250 should be placed immediately above or below the TV set/screen. This position ensures perfect integration between picture and sound, thus the optimum and most realistic experience.

The LCR 250 transducers are magnetically shielded so they will NOT interfere with the video signals of your TV.

ACCESSORIES

The Avant LCR 250 has table top stands as standard accessory items for bracket assembly (refer to Fig. 1 below)

FIG. 1: TABLE TOP MOUNT

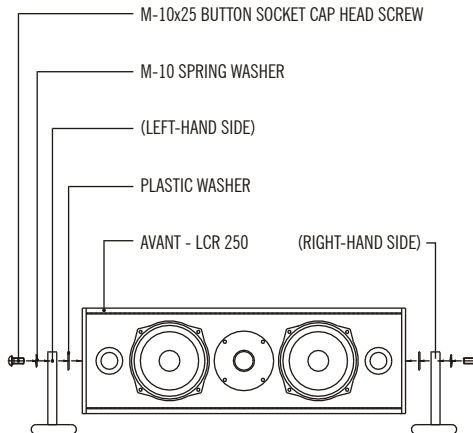

SPECIFICATIONS

DESCRIPTION:	2 way D'Appolito speaker system
CABINET - MATERIAL:	Aluminium extrusion with die cast end caps
TRANSDUCER COMPLEMENTS:	2 x 130mm woofer (shielded) 1 x 26mm Dome Tweeter (shielded)
NOMINAL IMPEDANCE:	8 Ohm
FREQ. RESPONSE (-3 dB):	95 Hz ~ 20 kHz
SENSITIVITY (1W, 1m):	90 dB
POWER HANDLING:	120 Watt
GRILL:	Acoustically transparent cloth stretched over perforated nylon grill
DIMENSIONS (HxWxD) mm:	a) 177 x 543 x 136 (cabinet only) b) 215 x 632 x 168 (with stand & terminal)
NET WEIGHT :	7.6 Kg

CARE & MAINTENANCE

All Sonodyne loudspeakers of the Avant range are manufactured with modern and thoroughly tested materials, which normally do not require any maintenance other than once in a while opening the front grille and vacuuming the cloth. If the loudspeaker's cabinet becomes greasy you may clean it by moistening a soft cloth with water and a mild soap to remove the dirt. Then, use a dry cloth to wipe and restore the original finish.

Please DO NOT use scouring powder, petrol, or any sort of alcohol or solvents to clean the loudspeaker. It will damage the finish permanently.



A product of the **Mukherjee Innovation Centre**

Manufactured by **Sonodyne Electronics Co. Pvt. Ltd.**, H.O.: 98 NB Block E New Alipore, Kolkata 700053, INDIA
Tel: 24570418, 24583406; Fax: +91 33 24787243; E-mail: response@sonodyne.org ; URL: www.sonodyne.com