



INSTALLATION AND OPERATION MANUAL

HSP SERIES

CONSTANT VOLTAGE POWER AMPLIFIERS

HS120P

WITH USB/RS232 CONTROL

HS250P

HS2120P

HS2250P

HS4120P

HS4250P



IMPORTANT SAFETY INFORMATION

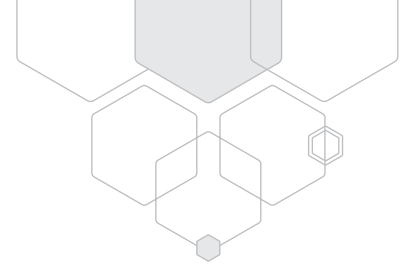

1. Read these instructions.
2. Keep these instructions.
3. Heed all warnings.
4. Follow all instructions.
5. Do not use this apparatus near water.
6. Clean only with dry cloth.
7. Do not block any ventilation openings. Install in accordance with the manufacturer's instructions.
8. Do not install near any heat sources such as radiators, heat registers, stoves, or other apparatus (including amplifiers) that produce heat.
9. Do not defeat the safety purpose of the polarized or grounding-type plug. A polarized plug has two blades with one wider than the other. A grounding type plug has two blades and a third grounding prong. The wide blade or the third prong are provided for your safety. If the provided plug does not fit into your outlet, consult an electrician for replacement of the obsolete outlet.
10. Protect the power cord from being walked on or pinched particularly at plugs, convenience receptacles, and the point where they exit from the apparatus.
11. Only use attachments/accessories specified by the manufacturer.
12. Use only with the cart, stand, tripod, bracket, or table specified by the manufacturer, or sold with the apparatus. When a cart is used, use caution when moving the cart/apparatus combination to avoid injury from tip-over.
13. Unplug this apparatus during lightning storms or when unused for long periods of time.
14. Refer all servicing to qualified service personnel. Servicing is required when the apparatus has been damaged in any way, such as power supply cord or plug is damaged, liquid has been spilled or objects have fallen into the apparatus, the apparatus has been exposed to rain or moisture, does not operate normally, or has been dropped.
15. This appliance must not be exposed to dripping or splashing water and no object filled with liquid such as vases shall be placed on the apparatus.
16. Plug this apparatus into the proper wall outlet and make the plug easily accessible for disconnection.
17. The mains plug is used to disconnect the device from the mains. It should remain readily available during intended use. In order to disconnect the apparatus from the mains completely, the mains plug should be disconnected from the mains socket outlet completely.
18. **WARNING:** To reduce the risk of fire or electric shock, do not expose this apparatus to rain or moisture.
19. An appliance with a protective earth terminal should be connected to a mains outlet with a protective earth connection.
20. The apparatus should be disconnected from the mains completely before connecting the speaker wiring. The copper wiring from the speaker outputs should not be allowed to come into direct contact with the device.



PRÉCAUTIONS DURANT UTILISATION

1. LISEZ ces instructions.
2. Tenez ces instructions.
3. Notez tous les avertissements.
4. Suivez toutes les avertissements.
5. N'utilisez pas ce produit près de l'eau (la piscine, la plage, le lac, etc.).
6. Nettoyez seulement avec une étoffe sèche.
7. Ne bloquez aucuns trous de ventilation. Installez en accord avec les instructions du fabricant.
8. N'installez près aucunes sources de chaleur comme radiateurs, registres de chaleur, fours ou les autres équipements (y compris ampli cateurs) qui produisent la chaleur.
9. Ne défaites pas le but de sécurité de la fiche polarisée ou base-type. Une fiche polarisée a deux tranchants avec un plus large que l'autre. Une fiche de base type a deux a deux tranchants et une troisième pointe de base, le tranchant large ou la troisième pointe est fourni pour votre sécurité. Si la fiche donnée ne conforme pas votre prise de contact, consultez un électricien pour remplacement de la prise de contact obsolète.
10. Protégez le cordon de secteur contre être marché dessus ou pincez en particulier aux fiches, aux douilles de convenance, et au point où ils sortent de l'appareil.
11. Seulement utilisez attachements/accessoires spécifiés par le fabricant.
12. Utilisez seulement avec un chariot, un stand, un trépied, un support ou une table indiquée par le fabricant, ou vendue avec l'appareil. Quand un chariot est utilisé, faites attention en déplaçant la combinaison d'appareil/chariot pour éviter de se déséquilibrer.
13. Arrachez la fiche du dispositif durant éclair et orage ou quand pas utilisé pour longues périodes de temps.
14. Référez au personnel qualifié de service pour toutes réparations. La réparation est donnée quand le système a été endommagé à n'importe façon, par exemple un fil ou une fiche endommagé(e) de la source d'alimentation. Avoir été exposé à pluie ou humidité, n'opère pas normalement, ou avoir été tombé.
15. L'appareil ne doit pas être exposé aux écoulements ou aux éclaboussures et aucun objet ne contenant de liquide, tel qu'un vase, ne doit être placé sur l'objet.
16. Branchez l'appareil à une source appropriée et faire que la prise à débrancher soit facilement accessible.
17. La prise du secteur ne doit pas être obstruée ou doit être facilement accessible pendant son utilisation. Pour être complètement déconnecté de l'alimentation d'entrée, la prise doit être débranchée du secteur.
18. **AVERTISSEMENT:** Pour éviter le risque d'incendie ou de chocs électriques, ne pas exposer cet appareil à la pluie ou à l'humidité.
19. Un appareil avec la borne de terre de protection doit être connecté au secteur avec la connexion de terre de protection.
20. Assurez-vous que l'appareil est hors tension avant de connecter les hauts parleurs. Vérifiez que la sortie des enceintes soit protégées contre un contact physique. Respecter les polarités des terminaux ainsi que le câblage des enceintes pendant le fonctionnement afin d'assurer une utilisation sécurisée.



INTRODUCTION & CONTENTS

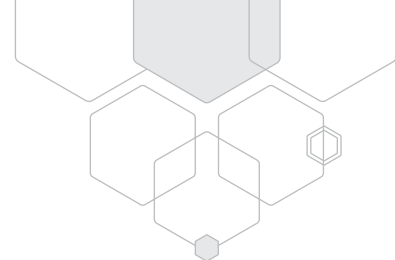

HSP SERIES

Congratulations on choosing Australian Monitor for your professional amplification requirements.

The design of our HSP series constant voltage power amplifiers embraces all the aspects of a well-designed amplifier. The visual design, mechanical, electrical and sonic parameters, along with our dedicated manufacturing process, have all been optimised to provide a professional tool that exhibits quality, reliability and longevity.

The HSP series amplifiers are 1 unit 1.75" high, 19" wide, or 2 unit 3.5" high, 19" wide rack mountable units depending on the model.

Models are available in 1, 2 and 4 channel versions. The HSP amplifier is fully controllable over the included USB and RS232 interface which provides configuration and monitoring capabilities. An included mini DSP also allows control of the volume, muting, compressor/limiter and input channel selection which feeds an efficient Class D amplifier to deliver 120W or 250W of output power per channel.

These amplifiers have been specifically designed to deliver their high power output with minimal distortion, and provide the critical degree of control required by your speakers.

Introduction	3
Features & Protection Features	4
Front Panel	5
Rear Panel	6
Software Setup	8
Installation	13
Basic Setup and Operation	16
Maintenance	17
Specifications	18
Serial Command Protocol	22

Revision 1.3: Sep 2019

WARNING

TO PREVENT FIRE OR SHOCK HAZARD, DO NOT USE THE PLUG WITH AN EXTENSION CORD, RECEPTACLE OR OTHER OUTLET UNLESS THE BLADES CAN BE FULLY INSERTED TO PREVENT BLADE EXPOSURE.

TO REDUCE THE RISK OF FIRE OR ELECTRIC SHOCK, DO NOT EXPOSE THIS APPLIANCE TO RAIN OR MOISTURE.

TO PREVENT ELECTRICAL SHOCK, MATCH WIDE BLADE PLUG TO WIDE SLOT & FULLY INSERT.

CAUTION

THESE SERVICING INSTRUCTIONS ARE FOR USE BY QUALIFIED SERVICE PERSONNEL ONLY. TO REDUCE THE RISK OF ELECTRIC SHOCK DO NOT PERFORM ANY SERVICING OTHER THAN THAT CONTAINED IN THE OPERATING INSTRUCTIONS UNLESS YOU ARE QUALIFIED TO DO SO.



The lightning flash with arrowhead symbol, within an equilateral triangle, is intended to alert the user to the presence of uninsulated "dangerous voltage" within the product's enclosure that may be of sufficient magnitude to constitute a risk of electric shock to persons.



WARNING

TO REDUCE THE RISK OF ELECTRIC SHOCK, DO NOT REMOVE COVER (OR BACK). NO USER SERVICEABLE PARTS INSIDE. REFER SERVICING TO QUALIFIED SERVICE PERSONNEL.



The exclamation point within an equilateral triangle is intended to alert the user to the presence of important operating and maintenance (servicing) instructions in the literature accompanying the appliance



For European Union countries: This symbol on the product or its packaging indicates that this product must not be disposed of with other waste. Instead, it is your responsibility to dispose of your waste equipment by handing it over to a designated collection point for the recycling of waste electrical and electronic equipment. Please contact your local authority for further details of your nearest designated collection point.

Rating plate and caution marking are marked on the back enclosure of the apparatus

FEATURES & PROTECTION FEATURES

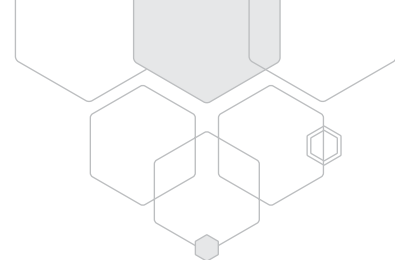

FEATURES

- Single Channel - HS120P- 1 x 120W, HS250P – 1 x 250W
- Dual Channel - HS2120P – 2 x120W, HS2250P - 2x250W
- Quad Channel - HS4120P – 4 x 120W, HS4250P – 4 x 250W
- Efficient Class-D amplification
- 4Ω/70V/100V output operation
- 1, 2 or 4 input to output channel variants with balanced input channels
- DSP provides
 - > Volume control
 - > High/Low Pass Filtering
 - > Compressor/Limiter
 - > Input/Output channel selection matrix
 - > Channel inversion
 - > Status monitoring
- PC controlled software graphical user interface control
- USB and RS232 interface for DSP configuration and overall product control
- Dedicated external Mute, Standby and Fault monitoring connector
- Amplifier and Signal status LED indicators
- Power factor corrected universal switch mode power supply (excluding HS120P)
- 1RU (1 and 2 channel models) / 2RU (4 channel models) height with front rack mount ears
- Fan cooled

PROTECTION FEATURES

- Clip protection
- Short-circuit protection
- Overload protection
- Thermal protection

HSP AMPLIFIER BLOCK DIAGRAM

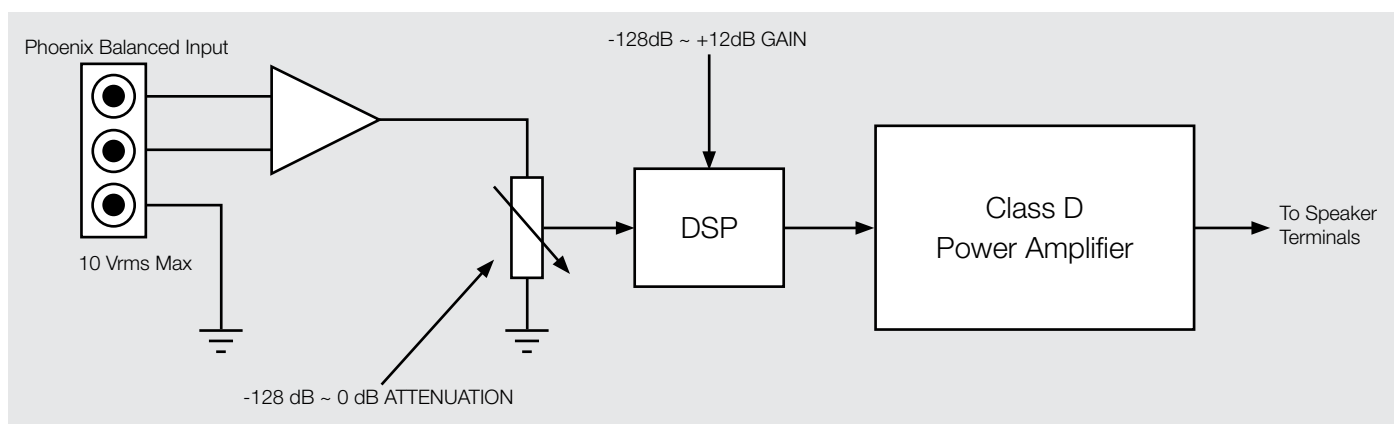

GLOSSARY

TERM	MEANING
DSP	Digital Signal Processor
USB	Universal Serial Bus
XLR	Audio electrical connector type
LED	Light Emitting Diode.
PHOENIX CONNECTOR	Terminal block connector type. Also known as a Euroblock.
DIP SWITCH	Dual in-line package switch. Used on the front and rear of the product to select various settings

FRONT PANEL

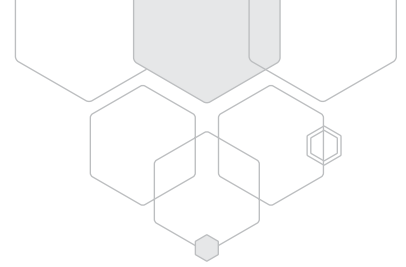

HSP 1 Channel 1RU shown in above example.

1 **USB COMMUNICATIONS PORT**
 Plug in the supplied USB Type A to Mini Type B connector into this port to communicate with the amplifier from the PC software application. The PC software application, downloadable from the Australian Monitor website, allows for real time monitoring of the amplifier inputs and outputs. The PC software application is also used to configure the DSP functionality to cater for the installation environment. Consult the Software Control Over USB setup section of this manual for further details of this control.

2 **LED INDICATORS**
STATUS INDICATOR
 This blue LED indicates various states of the amplifier.

LED	MEANING	INDICATION
Blue On	Normal Operation	LED solid on. Indicates that device is powered and that no faults exist.
Blue Slow Flash	Standby Mode	Flash LED: On for 50ms, Off for 4s
Blue Flash	Error Mode	LED Off for 2s followed by a flash count of the error code, On for 300ms, Off for 300ms. Multiple errors will be indicated in consecutive error sequences. Refer to the Fault Finding section of this manual to fix any errors displayed.

PROTECT INDICATOR
 The following table indicates the meaning of each protection mode

LED	MEANING
Yellow flashing	Amplifier temperature warm
Yellow on	Amplifier temperature hot
Red flashing	Amplifier over temperature*
Red on	Amplifier protect

See the Fault Finding section of this manual to fix any errors displayed.

* In the advent of a thermal overload, the internal operating temperature of the amplifier has exceeded a safe level of operation. The fan will continue to run and once the amplifier has cooled it will return to normal operation.

SIGNAL LED
 The following table indicates the meaning of the signal LED

LED	MEANING
Green flashing	Audio signal mute
Green on	Audio signal present

OUTPUT CLIP INDICATOR
 A red LED will illuminate when output signal clipping occurs.

3 **POWER SWITCH**
 Press the switch to the up position to power the unit on. At start-up (turn-on), the input to the amplifier is muted for approximately two seconds.

REAR PANEL

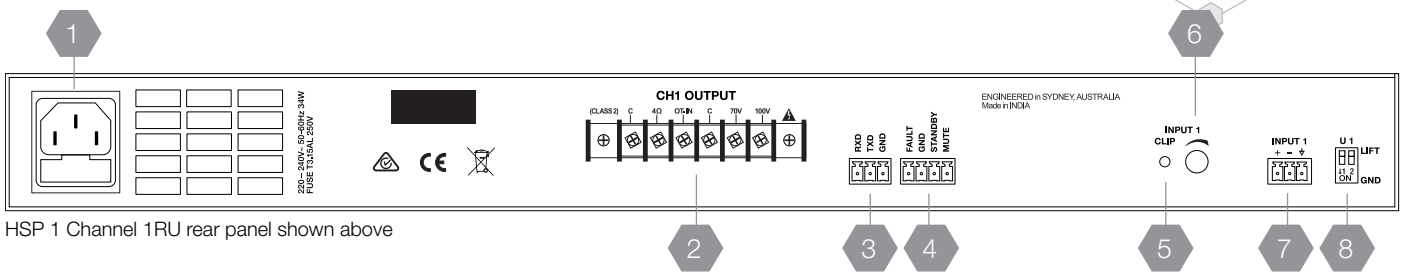

HSP 1 Channel 1RU rear panel shown above

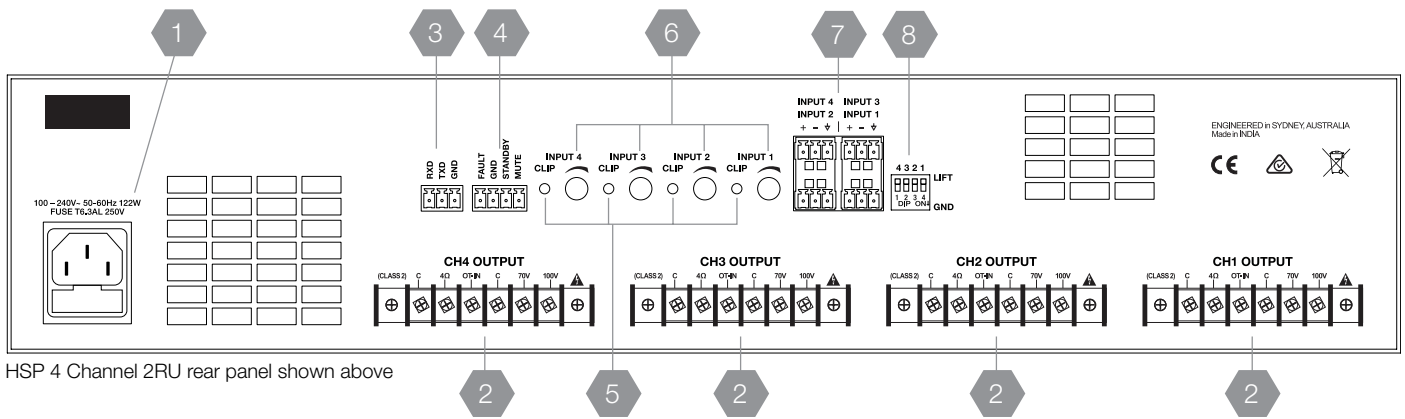

HSP 4 Channel 2RU rear panel shown above

- 1 MAINS INPUT CONNECTOR**
 Your amplifier is fitted with a standard IEC 60320-C14 socket for mains connection. Use the mains cable supplied to power up the unit.
NOTE: Your unit must always be earthed!
- 2 SPEAKER OUTPUT**
 The class D amplifier output features 100V Line, 70V Line or 4Ω low impedance operation.
IMPORTANT: Remove the speaker connector link if operating the amplifier in 4Ω operation.
NOTE: Only one output type should be used at a time.
- 3 RS232 COMMUNICATIONS PORT**
 The RS232 port is designed to be connected to an external control system or to a remote PC. Using an RS232 converter (not supplied), connect to this port to communicate with the amplifier from the PC software application or via serial commands. The PC software application allows for real time monitoring and configuration of the amplifier. Consult the Software Control Over RS232 setup section of this manual for further details of this control.
- 4 EXTERNAL MUTE, STANDBY AND FAULT**
 External Mute: Connect this input to ground (GND) to mute amplifier channels. Consult the EXTERNAL MUTE section of this manual for further detail of this control.

 Standby: Connect this input to ground (GND) to enable standby mode. Consult the STANDBY INPUT section of this manual for further detail of this control.

 Fault: This active low output indicates a fault in the amplifier. There are two possible faults that can be indicated:

 - The amplifier has gone into thermal shutdown due to a measured high temperature
 - The amplifier has detected an overload condition on the speaker terminals
 Consult the Fault section of this manual for further detail of this control.
- 5 INPUT CHANNEL CLIP LEDS**
 The input channel clip LEDs are used to indicate that the input signal is being clipped. If the input is clipping, reduce the signal by turning the attenuation pot counter-clockwise (when viewed from rear) until the clip LED ever so slightly turns on with an input source present.
 The input source should be representative of the audio that will be used in the system on a daily basis.

REAR PANEL (CONT.)

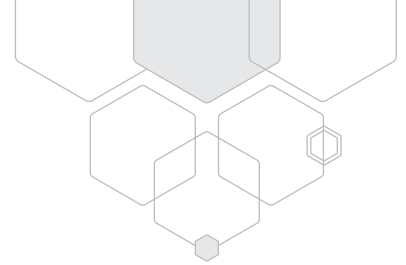

6 INPUT SIGNAL ATTENUATION POT
The fully clockwise position (when viewed from rear) of the input signal attenuation pot provides no attenuation (ie 0dB). Turning the pot counter clockwise provides a logarithmic attenuation all the way to -128dB.

7 PHOENIX BALANCED INPUT
A balanced male 3-pin (3.81mm) Phoenix type connector is provided on each input channel. Consult the **BALANCED INPUT WIRING** section of this manual for further detail of this control.

8 GROUND LIFT SWITCH
Use the DIP switches to control the grounding of the audio inputs. The switch for the given channel is pushed down to connect the input signal ground with the mains safety ground. The piano DIP switch is in the lift position (ie up) when the input ground needs to be lifted from the mains safety ground to prevent circulating earth loops.
If at anytime a hum or unwanted noise is experienced then the input should be configured so that the input signal ground is lifted from the mains safety earth. This minimises the circulating ground loop current by adding in an impedance which results in significantly less loop voltage drop being amplified by the amplifier.

Refer to diagram below which illustrates the above concept:

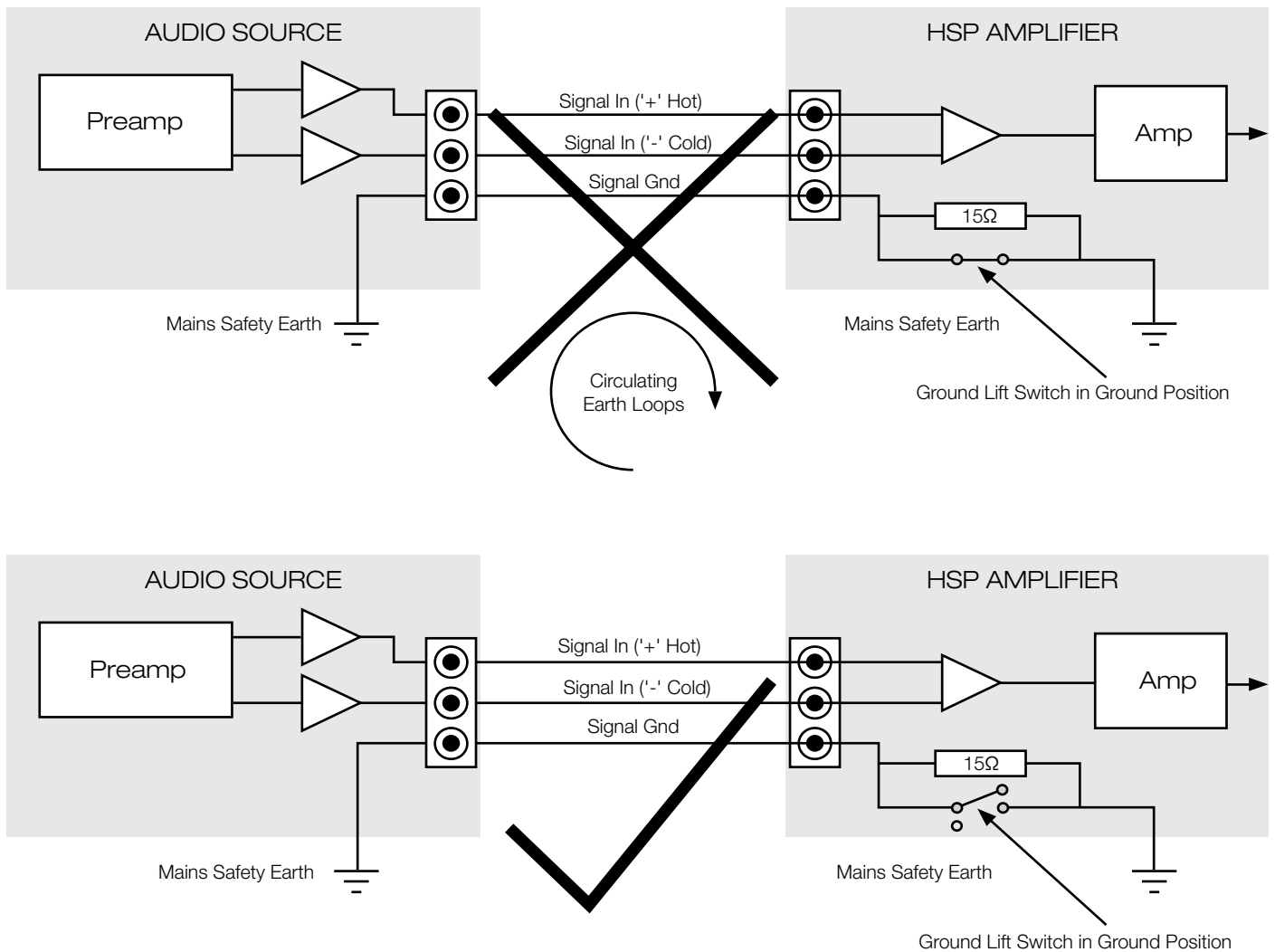

SOFTWARE SET-UP

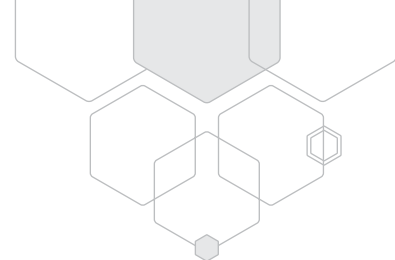

SUPPORTED OPERATING SYSTEMS

- Windows 10
- Windows 8
- Windows 7 (32/64 bit)
- Windows XP (32/64 bit)

SOFTWARE DOWNLOAD PROCEDURE

1. Navigate to: <http://www.australianmonitor.com.au/resources/>
Type the product name into the search box as follows (for example): HS120P
2. Select the latest version of the HSP Control Software Installer VX.X.0
3. Navigate to your downloads folder and double click on the installer to run
4. Plug in a USB/RS232 cable to the HSP power amplifier and turn the amplifier on
5. Launch the HSP Control Software and connect to the amplifier

SOFTWARE CONTROL OVER USB

1. Turn on the power to the HSP unit by pushing the front panel switch up.
2. Plug in the supplied USB cable to the HSP front panel and PC.
3. Open the software application HSP Control Software VX.X.X.
4. Upon successful connection the main application window will look like the image on the right. (Note: The number of channels displayed will depend on the HSP model):

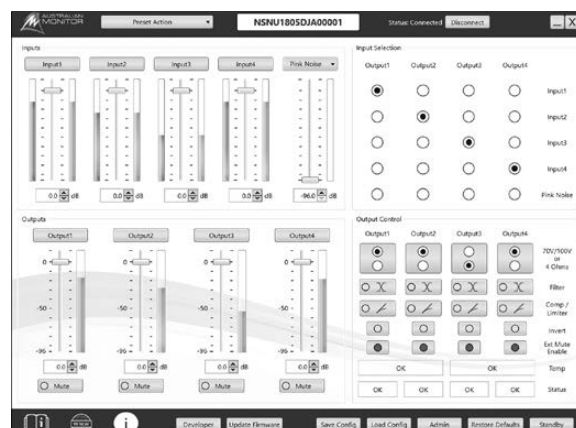

SOFTWARE CONTROL OVER RS232

The RS232 control port works in two ways

1. As an alternative control port to the front panel USB for longer distance control using the PC application.
2. To interface to an external control system using serial commands. i.e. Not using the PC application but directly controlling the unit and sending discrete commands.

RS232 CONNECTION SETUP

TXD	Transmit OUT of amplifier. Connect to RECEIVE of remote control system
RXD	Receive IN to amplifier. Connect to TRANSMIT of remote control system
COM PORT	Baud 115200, Data 8, Stop 1, Parity None, SETTINGS Flow None

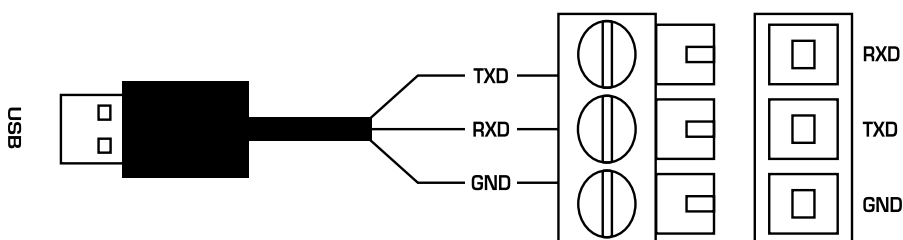

SOFTWARE SET-UP (CONT.)

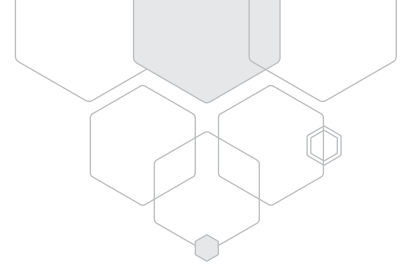

RS232 USING THE PC APPLICATION

1. Most modern PC's require a USB to RS232 converter for RS232 operation. A suggested RS232 to USB converter is the FTDI (USB-RS232-WE-1800-BT_5.0) which can be sourced through most online electronic component stores.
2. Wire up the USB to RS232 converter like the image at left [see page 8] using the supplied green 3-way Phoenix connector. Note it's important that the RXD and TXD of the HSP pins must join to the TXD and RXD of the converter respectively.
3. Turn on the power to the HSP unit by pushing the front panel switch up.
4. Plug in the supplied RS232 cable to the rear of the HSP unit and USB port to the PC.
5. Make sure the driver for the RS232 to USB converter cable has installed correctly. This can be checked by opening windows device manager. To do this select (Start -> System -> Device Manager) and then make sure there are no devices marked as inactive due to a missing driver.
6. Double click on the installed application HSP Control Software VX.X.X.
7. Select the USB to RS232 converter manufacturer from the dropdown menu. Note: if using the FTDI cable that is suggested above it will display as (USB Serial Port (COMXX)) where COMXX will display the COM port number chosen by the PC. See image below:
8. Upon successful connection the main application window will look like the image below (Note: The number of channels displayed will depend on the HSP model):

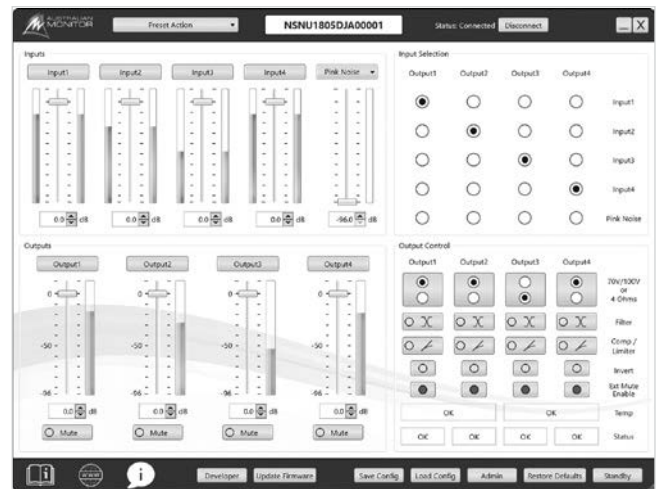

RS232 USING AN EXTERNAL CONTROL SYSTEM

1. Connect the external control system to the RS232 port of the amplifier.
2. Configure the RS232 port settings as per the setup information above
3. Referring to the serial command section, send and receive commands using the external control system.

Example command to enter standby: `set device mode standby true`

SOFTWARE SET-UP (CONT.)

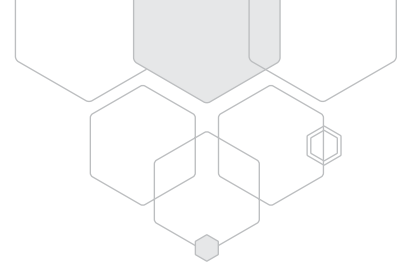

OUTPUT SPEAKER MODE

Selects the mode of operation for the amplifier.

- 70V/100V is for high impedance speaker applications
- 4Ω is for low impedance speakers applications.

The output mode determines when an internal 50Hz high pass filter is active. It is active for 70V/100V operation to prevent the output transformer from saturating, but can be turned off for low impedance applications give a greater frequency response.

Output Control



OUTPUT DEVELOPER MODE

A highly recommended method to easily understand the commands being sent and received by the amplifier is to turn on “Developer” mode on the PC application. This will open a second window that displays the commands being sent and received when the user interacts with the PC application. These commands can then be copied to an external control application without requiring a detailed understanding of the communication protocol.

NOTE: The “Developer” window is NOT supported in offline mode. You must be connected to an amplifier

Select the “Developer” mode button shown below



Interact with the application to see commands being printed to the “Developer” window

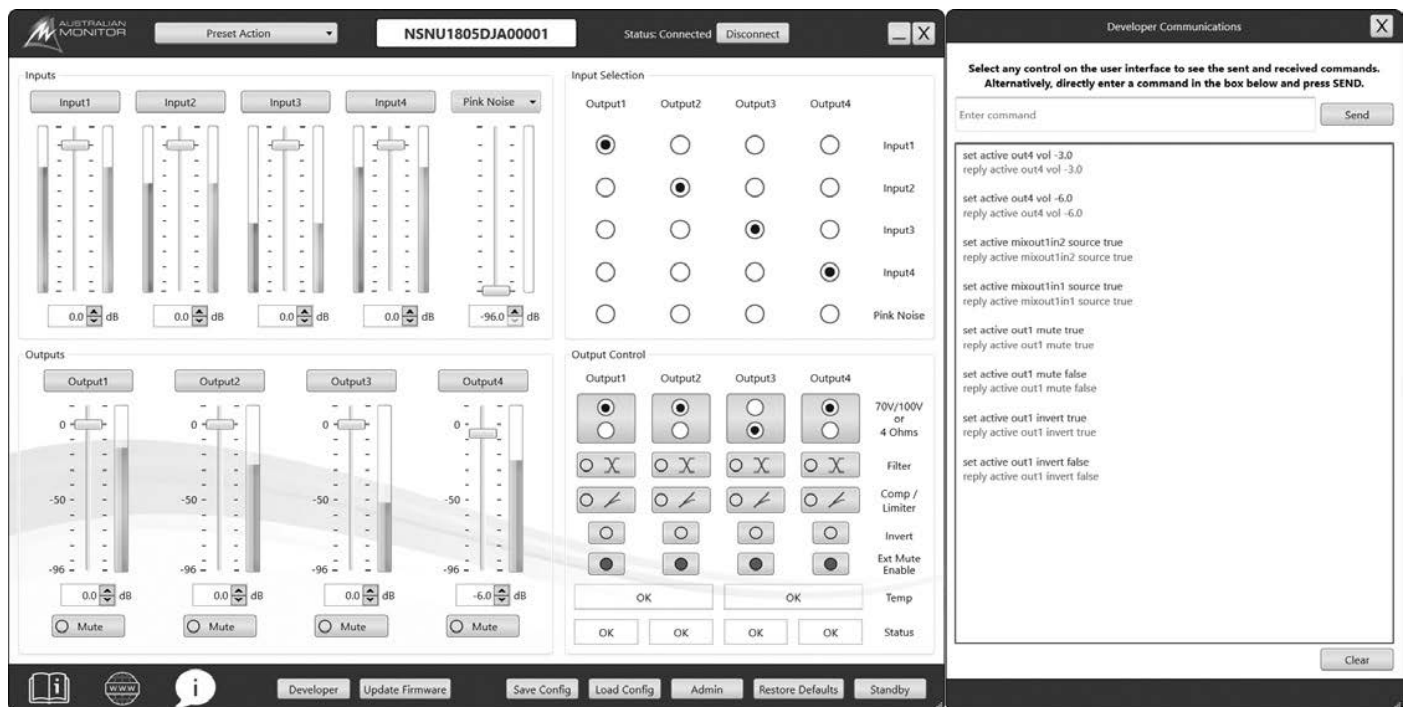

SOFTWARE SET-UP (CONT.)

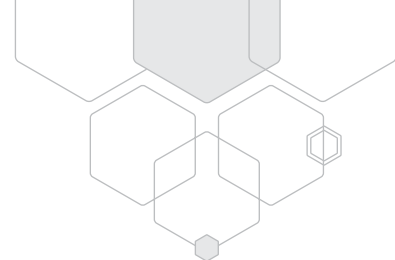

EXTERNAL MUTE

The external mute functionality is activated using the supplied 4-way Phoenix connector. Simply connect the MUTE to GND to mute channels of the amplifier. See connection diagram listed below for a simple connection:

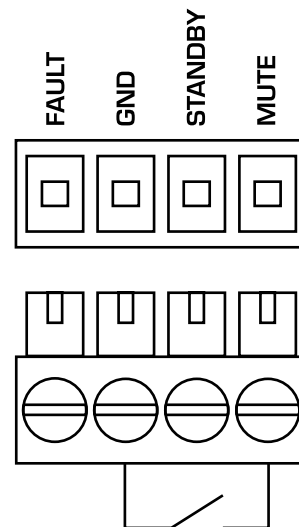

The PC application includes toggle buttons to select which amplifier channels are muted using the external mute trigger. Select or deselect the channels required in the application.



*4 channel product shown

STANDBY

The amplifier has three ways to enter or exit standby in the following priority:

- Priority 1 - External Input
- Priority 2 - Command Interface
- Priority 3 - Auto standby

- If priority 1 is released when the Command interface is enabled you will NOT exit standby. You must explicitly send a standby exit command.
- If Priority 1 and/or 2 is enabled and then consequently disabled the unit will always exit standby irrespective of priority 3 settings. However, if priority 3 is enabled it will then re-enter standby after the preset time has elapsed.

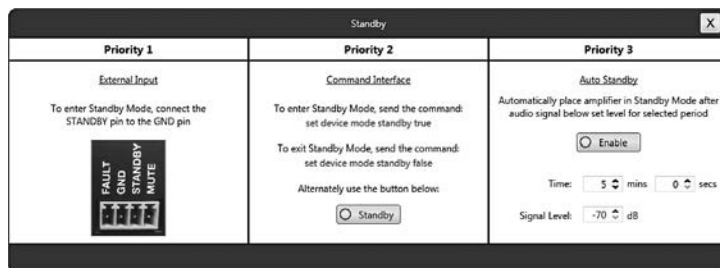

PASSWORD PROTECTION

To enable password protection on the amplifier, press on the Admin button on the main window, then click Enable to turn on the password protection functionality.

The default username and password are: Username - admin
Password - admin

SOFTWARE SET-UP (CONT.)

PRIORITY 1 - EXTERNAL INPUT

The standby function is activated using the supplied 4-way Phoenix connector. Simply connect the STANDBY to GND to put the amplifier into standby mode. See connection diagram listed below:

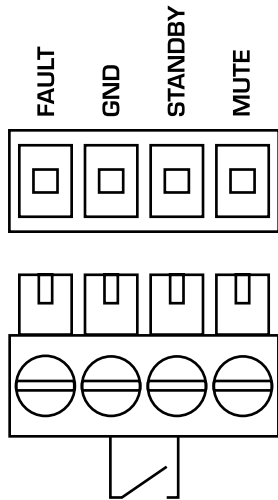

FAULT

The FAULT output will be set low (0V) under the following conditions:

- The amplifier has gone into thermal shutdown due to a measured high temperature
- The amplifier has detected an overload condition on the speaker terminals

The FAULT output is located on the rear of the HSP unit. Connect the FAULT and GND connection to any external control solution to read this signal.

The FAULT output is an open collector output with a 390R current limiting resistor in series.

Maximum voltage relative to GND	35V
Maximum current	100mA

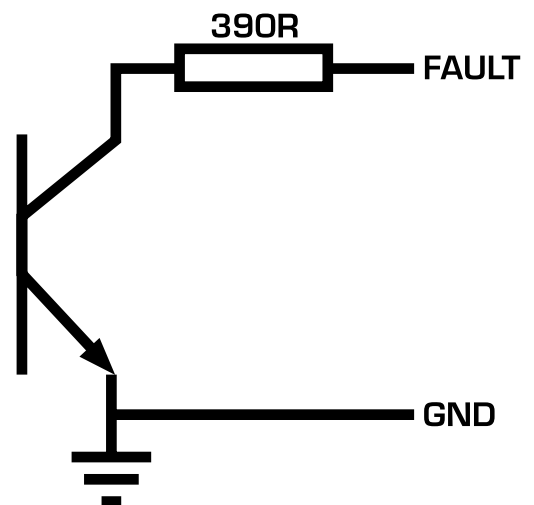

PRIORITY 2 - COMMAND

Send the following command using RS232

To enter standby: `set device mode standby true`

To exit standby: `set device mode standby false`

You can also enable/disable the software standby using the PC application.

Open the standby dialog box by selecting the “Standby” button and then select the Standby button under the priority 2 section.

PRIORITY 3 - AUTO STANDBY

The amplifier can enter and exit standby based on the presence of audio on any input. (Note: All input channels are summed together for detection)

Open the standby dialog box in the PC application by selecting the “Standby” button and set the time and audio threshold under the priority 3 section.

INSTALLATION

POWER REQUIREMENT

Power consumption for your model of the HSP series amplifier is indicated on the rear panel for 1/8th output power.

Ensure that your mains voltage is the same as the rear panel mains voltage marker ($\pm 10\%$)

MOUNTING

The HSP series amplifiers are one or two rack units high (1U) (2U) and will fit a standard EIA 19" or rack.

Typically amplifiers may be stacked directly on top of each other with no need for spacing between units, unless installed in high ambient temperature environments where a single rack unit space between amplifiers will assist cooling further.

COOLING

The HS120P is convection cooled and does not require any special consideration.

The HS250P, HS2120P, HS2250P, HS4120P and HS4250P amplifiers are cooled by axial fans which draw air inside the amplifier and expel the heated air outside the amplifier. These amplifiers offer variable speed fans which run at half speed up to full speed when the internal heatsink temperature increases.

An unrestricted airflow into and out from the amplifier must be provided. Any restriction of the air flow will cause heat to build up within the unit and possibly force the unit into its thermal shutdown mode.

If the amplifiers are to be operated in an environment where the airflow is restricted such as sealed racks, cooling should be supplemented by extra cooling fans to evacuate the heated air and aid the flow of cool air through the unit.

BALANCED INPUT WIRING

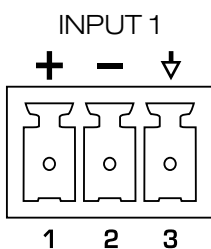

IMPORTANT: Do not directly connect pin 3 on the amplifier's input to the amplifier's chassis, speaker ground or power ground!



WARNING: Input signal ground should NOT be used as a safety ground (earth).

The balanced input to the amplifier is 3-pin configuration and requires all three pins to be connected. Only high quality twin-core shielded cable should be used.

Pin 1 is the left most pin when viewed from the back of product.

Pin 1 = Hot (non-inverting or in phase)

Pin 2 = Cold (inverting or reverse phase)

Pin 3 = Signal Ground

When wiring from an unbalanced source you must ensure that pin 2 is connected to pin 3 (Signal Ground), either by linking the pins in the input connector or by the source equipment's output wiring.

When wiring for an unbalanced source:

Pin 1 = Hot (non-inverting or in phase)

Pin 2 = Signal Ground

Pin 3 = Signal Ground

OUTPUT WIRING

When wiring to your speakers always use the largest gauge wire your connector will accept. The longer the speaker lead the greater the losses which will result in reduced power and less damping at the load. We recommend using a heavy duty, two core flex (four core flex if bi-amping) 10 to 12 gauge (2mm² to 2.5mm² or 50/0.25 or equivalent) as a minimum.

INSTALLATION (CONT.)

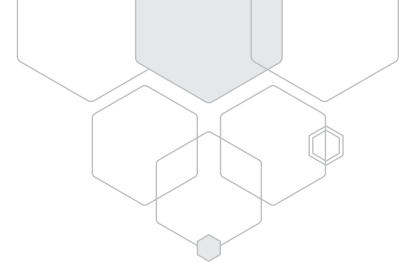

SPEAKER OUTPUTS

The amplifier output has a 6 pin output screw terminal with a pre-fitted link between the 4Ω and the high impedance output.

4Ω OR 8Ω OPERATION

- Remove the link between 4Ω and the OT-IN
- Connect your speaker to the LOW IMPEDANCE OUTPUT 'C' and '4Ω' connections

70V

- Fit the link between 4Ω and the OT-IN. (This connects the amplifier output to the input of the 70/100V transformer)
- Connect your speaker to the HIGH IMPEDANCE OUTPUT 'C' and '70V' connections

100V

- Fit the link between 4Ω and the OT-IN. (This connects the amplifier output to the input of the 70/100V transformer)
- Connect your speaker to the HIGH IMPEDANCE OUTPUT 'C' and '100V' connections

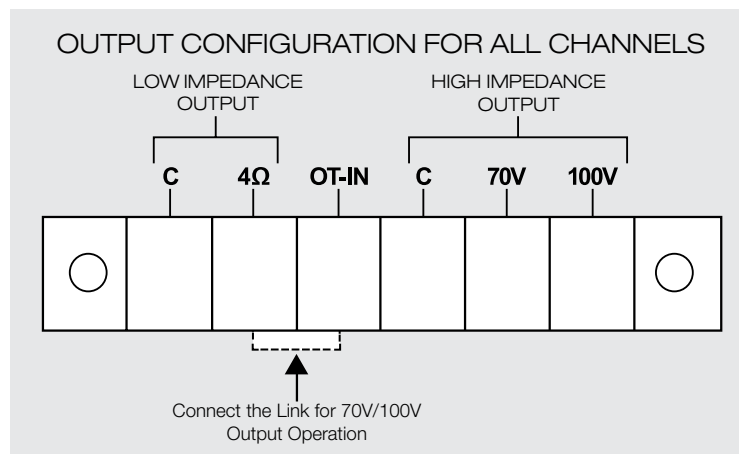
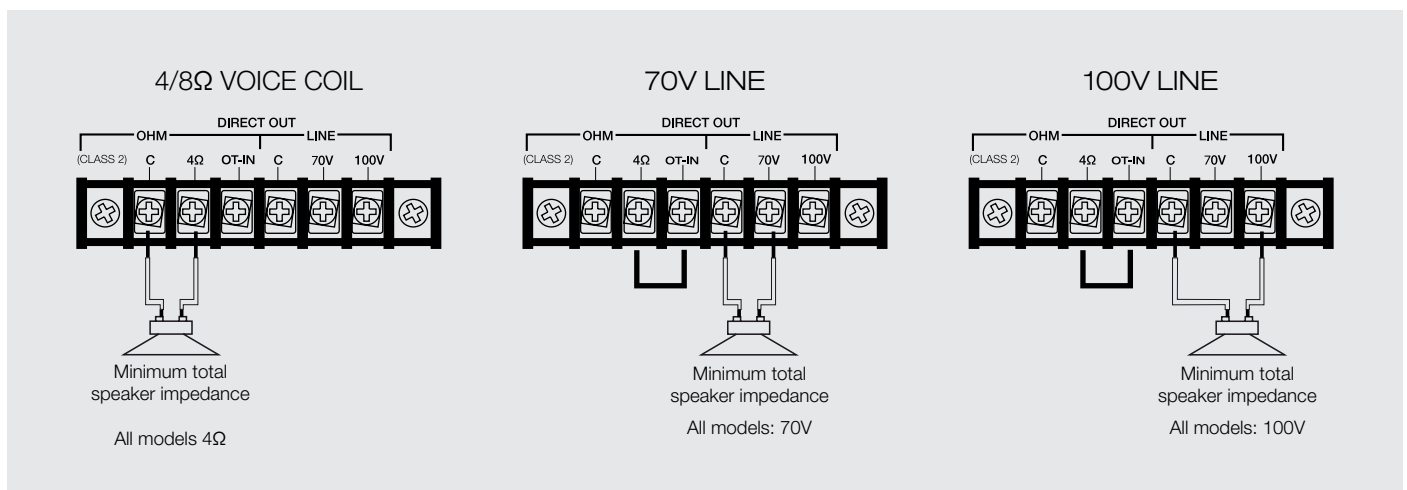

BASIC SETUP & OPERATION

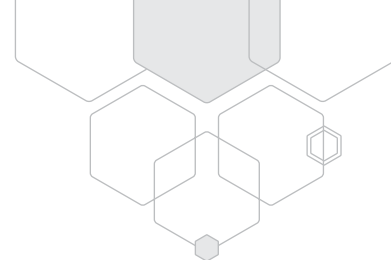

FAULT FINDING

STATUS INDICATOR

If the blue STATUS LED is flashing instead of remaining on then a specific system state is being displayed. See the table below on the meaning and of the system state.

The Status LED should indicate the following:

LED	MEANING	INDICATION
Blue On	Normal Operation	LED solid on. Indicates that device is powered and that no faults exist.
Blue Slow Flash	Standby Mode	Flash LED: On for 50ms, Off for 4s
Blue Flash	Error Mode	LED Off for 2s followed by a flash count of the error code, On for 300ms, Off for 300ms. Multiple errors will be indicated in consecutive error sequences. Refer to table below for list of error codes.

The list of error codes is:

ERROR CODE	STATUS LED ERROR FLASH COUNT
Configuration failure	1
Nor Flash image failure	2
Nor Flash read/write failure	3
Power Amplifier initialisation failure	4
DSP failure	5
Bootloader failure	6

PROTECT INDICATOR

The following table indicates the meaning of each protection mode

LED	MEANING	RESOLUTION
Yellow flashing	Amplifier temperature warm	None required
Yellow on	Amplifier temperature hot	None required
Red flashing	Amplifier over temperature*	The amplifier has shutdown. It will automatically restart once it has cooled down
Red on	Amplifier protect	Check the speakers connected to the amplifier are correctly wired. Power cycle the unit and retry.

* In the advent of a thermal overload, the internal operating temperature of the amplifier has exceeded a safe level of operation. The fan will continue to run and once the amplifier has cooled it will return to normal operation.

SIGNAL INDICATOR

The following table indicates the meaning of each signal mode

LED	MEANING	RESOLUTION
Green on	Audio signal present	None required
Green off	No audio signal present	Increase the input audio level
Green flashing	Amplifier channel is set to mute	Unmute the channel using the Web application

MAINTENANCE FIRE REGULATION COMPLIANCE

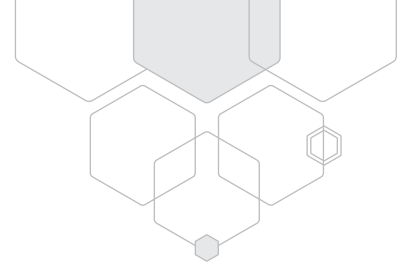

MAINTENANCE

Only competent or qualified persons should attempt any service or maintenance of your amplifier. Your ISP amplifier will need minimal maintenance. No internal adjustments need to be made to the unit to maintain optimum performance. To provide years of unhindered operation we suggest a maintenance inspection be carried out on annually.

FIRE REGULATION COMPLIANCE

This amplifier is not certified to fire regulations standards such as EN 54-16

SPECIFICATIONS



MODEL	HS120P	HS250P	HS2120P	HS2250P	HS4120P	HS4250P	CONDITIONS/COMMENTS
TOPOLOGY	Class-D	Class-D	Class-D	Class-D	Class-D	Class-D	
CHANNELS	1	1	2	2	4	4	
POWER OUTPUT (PER CHANNEL) 4Ω 70V 100V	136W 124W 131W	260W 244W 256W	136W 124W 131W	259W 245W 257W	135W 123W 130W	242W 243W 242W	1kHz, 1%THD, -10W/+30W, CEA-2006, one channel driven
MAXIMUM OUTPUT LEVEL (dBV/Vrms)	27dBV (22.4Vrms)	30dBV (31.6Vrms)	27dBV (22.4Vrms)	30dBV (31.6Vrms)	27dBV (22.4Vrms)	30dBV	20Hz - 20kHz, <1%THD, 4Ω
SYSTEM GAIN	27dB	30dB	27dB	30dB	27dB	30dB	
FREQ. RESPONSE 4Ω 70V 100V	20Hz ~ 20kHz 100Hz ~ 16kHz 100Hz ~ 16kHz						3dB below clipping, +0/-3dB.±5Hz 3dB below clipping, +0/-3dB.±5Hz Low Frequency ±2kHz High Frequency
SIGNAL TO NOISE RATIO	> 94dB	> 96dB	> 96dB	> 97dB	> 92dB	> 91dB	Max Output, 1kHz, 20kHz BW, A-Weighted
THD+N. 4Ω, 1kHz	< 0.2%	< 0.2%	< 0.2%	< 0.2%	< 0.2%	< 0.25%	3dB below clipping, 1kHz, 20kHz BW, Unity Gain, A-Weighted
4Ω, 20Hz~20kHz	< 0.2%	< 0.2%	< 0.2%	< 0.2%	< 0.2%	< 0.3%	3dB below clipping, 20Hz ~ 20kHz, 20kHz BW, Unity Gain, A-Weighted
70V, 1kHz	< 0.2%	< 0.2%	< 0.2%	< 0.3%	< 0.2%	< 0.25%	3dB below clipping, 1kHz, 20kHz BW, Unity Gain, A-Weighted
70V, 20Hz~20kHz	< 0.2%	< 0.2%	< 0.2%	< 0.3%	< 0.2%	< 0.3%	3dB below clipping, 100Hz ~ 16kHz, 16kHz BW, Unity Gain
100V, 1kHz	< 0.2%	< 0.2%	< 0.2%	< 0.3%	< 0.2%	< 0.3%	3dB below clipping, 1kHz, 20kHz BW, Unity Gain, A-Weighted
100V, 20Hz~20kHz	< 0.2%	< 0.2%	< 0.2%	< 0.3%	< 0.2%	< 0.3%	3dB below clipping, 100Hz ~ 16kHz, 16kHz BW, Unity Gain
INTERMODULATION DISTORTION - SMPTE, 4Ω	0.09%	0.39%	0.06%	0.59%	0.10%	0.40%	60Hz/7kHz, 4:1, 3dB below clipping
ITU-R (CCIF), 4Ω	0.24%	0.48%	0.40%	0.30%	0.30%	0.46%	19kHz/20kHz, 1:1, 3dB below clipping
DAMPING FACTOR 4Ω	> 30						20Hz ~ 1kHz
DC OUTPUT OFFSET	< 30 mV						
CHANNEL SEPARATION (CH-TO-CH) 4Ω	NA	NA	-74dB -56dB	-72dB -60dB	-69dB -59dB	-60dB -58dB	Max Output, one channel driven 20Hz ~ 1kHz
(CH-TO-CH) 70/100V	NA	NA	-80dB -57dB	-72dB -60dB	-68dB -56dB	-63dB -61dB	1kHz ~ 20kHz Max Output, one channel driven 100Hz ~ 1kHz 1kHz ~ 16kHz

SPECIFICATIONS (CONT.)

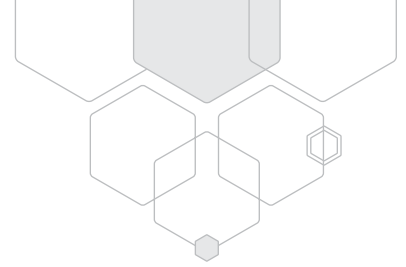

MODEL	HS120P	HS250P	HS2120P	HS2250P	HS4120P	HS4250P	CONDITIONS/COMMENTS
INPUT/OUTPUT							
AUDIO INPUT	Balanced Phoenix Input per channel						
DATA/CONTROL	USB Mini Type B. RS232 (TX,RX,GND). 3 pin 3.81mm Euroblock connector. Logic (Fault, Mute, Standby, GND). 4 pin 3.81mm Euroblock connector. Ground Lift.						
SPEAKER OUTPUT	6 pin Screw Terminal per channel						
SENSITIVITY							
AUDIO INPUT SENSITIVITY	1Vrms						Input Level potentiometer set to Max, Unity Gain
AUDIO INPUT MAXIMUM LEVEL	10Vrms						Input Level potentiometer set 20dB below Max level, Unity Gain
INPUT LEVEL ADJUSTMENT (REAR PANEL)	From -inf to 0dB						Unity Gain
DSP							
	Input channel selector Input volume control per channel High or Low pass filter Compressor/Limiter Output volume control per channel Mute Invert Input and output level meters Internal Tone Generator Internal Pink Noise Generator						
MISCELLANEOUS							
INPUT IMPEDANCE	20kΩ 10kΩ						Balanced, line-to-line Unbalanced, lint-to-GND
INPUT CMRR	> 55dB						20Hz ~ 20kHz
INPUT SIGNAL DETECTION THRESHOLD	-80dBV						
LED STATUS	Signal - Green Clip - Red Protect - Yellow Status - Blue						
OVERLOAD PROTECTION	Temperature, Over/Under Voltage, Short						
POWER REQUIREMENTS							
AC INPUT	220- 240Vac, 50~60Hz						±10%
AC POWER FACTOR	>0.55	>0.96	>0.97	>0.97	>0.96	>0.95	Max Output, 1kHz, 230Vac
AC INPUT CONNECTOR	IEC 60320-C14						
AC MAINS FUSE	T3.15AL 250V	T5AL 250V	T5AL 250V	T6.3AL 250V	T6.3AL 250V	T8AL 250V	
MAX INRUSH CURRENT	60A	70A					230VAC, 50Hz

SPECIFICATIONS (CONT.)

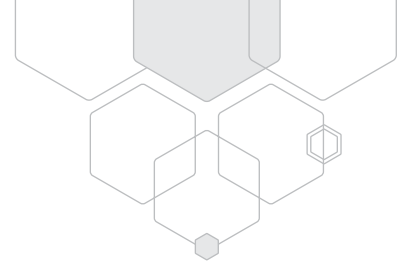

MODEL	HS120P	HS250P	HS2120P	HS2250P	HS4120P	HS4250P	CONDITIONS/COMMENTS
RMS CURRENT DRAW							
STANDBY	0.08A	0.154A	0.138A	0.190A	0.185A	0.2A	230Vac, 50Hz, 100V Output, 1kHz, Sine
IDLE	0.112A	0.187A	0.173A	0.207A	0.226A	0.247A	
1/8TH POWER	0.255A	0.337A	0.315A	0.535A	0.569A	1.006A	
1/3 POWER	0.510A	0.603A	0.580A	1.107A	1.137A	2.18A	
FULL POWER	1.257A	1.341A	1.478A	2.50A	2.33A	3.80A	
POWER CONSUMPTION							
STANDBY	6W	14W	12W	17W	16W	25W	230Vac, 50Hz, 100V Output, 1kHz Sine HS120P = 1 x 115W HS250P = 1 x 217W HS2120P = 2 x 120W HS2250P = 2 x 192W HS4120P = 4 x 90W HS4250P = 4 x 150W
IDLE	12W	19W	17W	23W	29W	37W	
1/8TH POWER	34W	65W	62W	114W	122W	213W	
1/3 POWER	69W	136W	132W	257W	263W	498W	
FULL POWER	174W	319W	358W	589W	554W	896W	
EFFICIENCY							
1/8TH POWER	68%	68%	67%	69%	65%	71%	230Vac, 50Hz, 100V Output HS120P = 1 x 115W HS250P = 1 x 217W HS2120P = 2 x 120W HS2250P = 2 x 192W HS4120P = 4 x 90W HS4250P = 4 x 150W
1/3 POWER	70%	71%	70%	71%	68%	72%	
FULL POWER	71%	72%	70%	68%	69%	70%	
THERMAL DISSIPATION							
STANDBY	20	48	39	58	55	85	Excludes Load Power (1W = 3.412BTU/Hr)
IDLE	41	65	59	78	99	126	
1/8TH POWER	101	191	183	326	356	602	
1/3 POWER	195	381	370	710	737	1366	
FULL POWER	201	348	403	699	662	1010	

SPECIFICATIONS (CONT.)

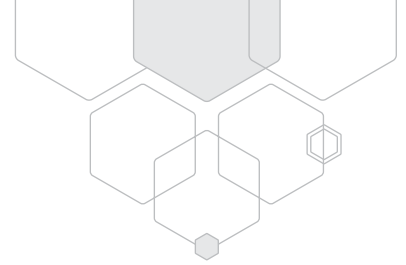

MODEL	HS120P	HS250P	HS2120P	HS2250P	HS4120P	HS4250P	CONDITIONS/ COMMENTS
WEIGHTS & DIMENSIONS							
PRODUCT DIMENSIONS W x D x H (WITH RACK EARS)	483mm x 325mm x 44.5mm (19.0" x 12.8" x 1.75")				483mm x 389mm x 89mm (19.0" x 15.32" x 3.50")		
PRODUCT DIMENSIONS W x D x H (WITHOUT RACK EARS)	435mm x 325mm x 44.5mm (17.13" x 12.8" x 1.75")				435mm x 389mm x 89mm (17.13" x 15.32" x 3.50")		
SHIPPING DIMENSIONS W x D x H	525mm x 425mm x 120mm (20.7 x 16.7" x 4.7")				546mm x 491mm x 197mm (21.5" x 19.3" x 7.8")		
NET WEIGHT	5.0Kg (11.02 lbs)	6.4 Kg (14.11 lbs)	7.2 Kg (15.87 lbs)	9.0 Kg (19.84 lbs)	14.0 Kg (30.86 lbs)	16.0 Kg (35.27 lbs)	
SHIPPING WEIGHT	8.0 Kg (17.7 lbs)	9.0 Kg (19.9 lbs)	9.8 Kg (21.7 lbs)	11.2 Kg (24.7 lbs)	15.6 Kg (34.5 lbs)	18.6 Kg (41.1 lbs)	
MOUNTING	1RU				2RU		
OPERATING TEMPERATURE	0°C to 40°C (95% RH)						
COOLING SYSTEM	Convection cooled	Fan assisted convection cooling					
FAN NOISE	NA		60dBA			Noise measured at 20cm from fan intake	
FINISH	Powder coated steel						
COLOUR	Black						
ACCESSORIES	IEC Mains cable. Rubber Feet x 4, 1x3 euroblock socket per channel, One 1x3 and One 1x 4 euroblock socket, Rack mount support						
APPROVALS	CE, IEC, RCM						
SUPPORTED OPERATING SYSTEMS	Windows 10, Windows 8, Windows 7 (32/64), Windows XP (32/64)						

Due to continuous improvements, all specifications are subject to change

SERIAL COMMAND PROTOCOL

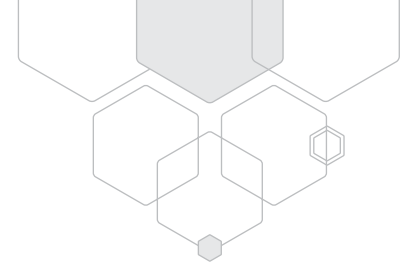

SERIAL COMMAND MESSAGE FORMAT

MESSAGE FORMAT						
operation	section	group	param	sub	ssub	value

- Operation is “get”, “set” or “reply”
- Supported content for section, group, param, sub, ssub and value message fields are as per the Australian Monitor Interface Protocol Specification.
- Message fields operation, section, group & param are mandatory, sub & ssub fields are optional.
- Value field applies only to “set” & “reply” operations.
- Wildcard “all” is available for message fields param, sub or ssub to provide access to first-level object members only.
- Message fields are separated with a space character (0x20 in hex).
- Messages should be terminated with a carriage return character (0x0D in hex), line feed (0x0A in hex) or both.
- Message replies are terminated with a carriage return character (0x0D in hex) and line feed (0x0A in hex).
- For “reply” operation, in case of failure, value field will contain the text “error”.
- For “reply” operation, in case of success, value field will contain the requested/updated item.

EXAMPLE: COMMAND: ‘set active in2 vol -65.0 CR LF’
 RESPONSE: ‘reply active in2 vol -65.0 CR LF’

EXAMPLE COMMANDS

	operation	section	group	param	sub	ssub	value
Set input 1 volume of preset 1 to -20dB	set	preset1	in1	vol			-20.0
	reply	preset1	in1	vol			-20.0
Set output 1 volume to -40dB	set	active	out1	vol			-40
	reply	active	out1	vol			-40
Mute output 4	set	active	out4	mute			true
	reply	active	out4	mute			true
Set output 1 to use input 4 source	set	active	mixout1in4	source			true
	reply	active	mixout1in4	source			true
Get the fault status of output 3 amplifier	get	active	out3	amp	status	fault	
	reply	active	out3	amp	status	fault	false
Save current configuration to preset 1	set	device	preset	save			1
	reply	device	preset	save			1
Recall preset 1	set	device	preset	recall			1
	reply	device	preset	recall			1
Enter standby mode	set	device	mode	standby			true
	reply	device	mode	standby			true
Get product serial number	get	device	version	serial			
	reply	device	version	serial			NSNU1807DJA00001
Set input 1 volume of preset 1 to -20dB	set	preset1	in1	vol			-20.0
	reply	preset1	in1	vol			-20.0
Set the username to “admin”	set	device	security	user1	name		admin
	reply	device	security	user1	name		admin
Log in with username and password “admin”	set	device	security	login			admin,admin
	reply	device	security	login			admin,admin
Reset the device	set	device	mode	reset			true
	reply	device	mode	reset			true

SERIAL COMMAND PROTOCOL (CONT)

Section	Group	Param	Sub	Ssub	Value Type	Value Range	Description	Comment	Operation Permission
Device	Version	serial			Object		Device section		-
					Object		Version Group		-
					string		Serial Number		N
		pcbrev			array [numpcbrev], unsigned 8-bit number	0..99	PCB revision array: Array Element 0 = Microcontroller PCB revision Array Element 1 = Front PCB revision Array Element 2 = Amplifier Module 1 PCB revision Array Element 3 = Amplifier Module 2 PCB revision	Array of PCB revision numbers. Value of 255 = PCB unknown	N
		hardware			unsigned 8-bit number	1..32	Hardware ID	Command Deprecated. Use 'pcbrev' command	N
		amp			unsigned 8-bit number	1..32	Amplifier ID	Command Deprecated. Use 'pcbrev' command	N
		app			array[3], unsigned 8-bit number	0..255	Application firmware version	'pcbrev' command format: major.minor.build	N
		boot			array[3], unsigned 8-bit number	0..255	Bootloader firmware version	format: major.minor.build	N
		dsp			array[3], unsigned 8-bit number	0..255	DSP firmware version	format: major.minor.build	N
		json			array[3], unsigned 8-bit number	0..255	JSON Interface Protocol Specification version	format: major.minor.build	N
	Config				Object		Configuration Group		-
		name			string	32 bytes, UTF-8	Device name	default to serial number, no space or comma in name	S
		numinput			unsigned 8-bit number	0..255	Total Number of inputs		N
		numoutput			unsigned 8-bit number	0..255	Total Number of outputs		N
		numfilterout			unsigned 8-bit number	0..255	Number of filters per output		N
		numpreset			unsigned 8-bit number	0..255	Number of Presets		N
		numuser			unsigned 8-bit number	0..255	Number of Security Users		N
		numpcbrev			unsigned 8-bit number	0..255	Number of PCB revision numbers		N
	Mode				Object		Mode Group		-
		reset			bool	true/false	Reset device action flag	reset action will disconnect communication	S
		factory			char	a, c, p	Factory Reset device action: all, current config, presets	reset action will disconnect communication	S
		standby			bool	true/false	Standby mode action flag	enter / exit Standby Mode	S
		autostandby			bool	true/false	Auto standby mode action flag	enable / disable Auto Standby Mode	S
		autotime			unsigned 16-bit number	0..59,999s	Auto standby time		S
		autolevel			signed 8-bit number	-70dB..0dB	Auto standby threshold level		S
		softstart			unsigned 8-bit number	0..255 s	Audio soft start period	output volumes ramp up over soft start period after power up or exit standby	S

SERIAL COMMAND PROTOCOL (CONT)

Section	Group	Param	Sub	Ssub	Value Type	Value Range	Description	Comment	Operation Permission No Access Unsecure Secure Admin Set Get
		status			object		Device Mode Status information		-
			standby		bool	true/false	Standby mode status flag	Standby mode may have multiple triggers	N S
	Preset				Object		Preset Group		-
		save			unsigned 8-bit number	1..numpreset	Save active audio configuration to Preset		S N
		recall			unsigned 8-bit number	1..numpreset	Recall audio configuration from Preset		S N
		name			array[numpreset], string		Preset name array		-
		...					as per nameX		-
		nameX			string	32 bytes, UTF-8	Preset name where X = 1..numpreset	No space or comma in name	S
	Security				Object		Security Group		
		enable			bool	true/false	Security enable flag	default: false	A U
		login			array[2], string	32 bytes, UTF-8	Login array	No space or comma in username or password. Format: username,password	U N
		user			array[numuser], object		User array		-
		...					as per userX		-
		userX			object		User X where X = 1..numuser		-
			id		unsigned 8-bit number	1..numuser	User ID index		N A
			name		string	32 bytes, UTF-8	username	default: admin	A A
			password		string	32 bytes, UTF-8	password	default: admin	A A
			admin		bool	true/false	Admin permission flag		A A
			timeout		unsigned 16-bit number	10..65535 s	Login active time period	display as hours, minutes & seconds	A A
Active					Object		Active Audio Processing Section		-
	in				array[numinput], object		Input Group array		-
		...					as per inX		-
	inX				object		Config for Input X where X = 1..numinput		-
		id			unsigned 8-bit number	1..numinput	Input ID index		N S
		name			string	32 bytes, UTF-8	input name	No space or comma in name	S S
		mode			char	m,l,p,s,3,n,w,t	Input mode: mic, line, paging, stereo, MP, pink noise, white noise, test tone		S S
		vol			float (32-bit) number	-96.0dB..12.0dB	Volume		S S
			up		oat (32-bit) number	> 0.0dB	Increase volume by specified value		S N
			down		oat (32-bit) number	> 0.0dB	Decrease volume by specified value		S N
		freq			unsigned 16-bit number	1Hz..20kHz	Frequency (mode = t)	Sine wave test tone frequency	S S
		status			object		Input Status information		

SERIAL COMMAND PROTOCOL (CONT)

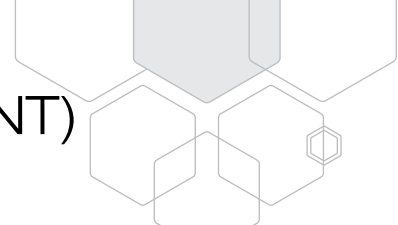

Section	Group	Param	Sub	Ssub	Value Type	Value Range	Description	Comment	Operation Permission
			level		signed 8-bit number	-96.0dB..12.0dB	Level in meter status		N S
			level		signed 8-bit number	-96.0dB..12.0dB	Level out meter status		N S
	mixoutXinY				object		Mixer config for Output X Input Y where X = 1..numoutput, Y = 1..numinput		- -
		idout			unsigned 8-bit number	1..numoutput	Output ID index		N S
		idin			unsigned 8-bit number	1..numoutput	Input ID index		N S
		source			bool	true/false	Source select	Input source selection for Output (single Input selection, no mixing)	S S
	out				array[numoutput], object		Output Group array		- -
		...					as per outX		- -
	outX				object		Config for Output X where X = 1..numoutput		- -
		id			unsigned 8-bit number	1..numoutput	Output ID index		N S
		name			string	32 bytes, UTF-8	Output name		S S
		type			unsigned 8-bit number	4, 70, 100	Output type: 4Ω, 70V, 100V		S S
		invert			bool	true/false	Invert enable flag		S S
		mute			bool	true/false	Mute enable flag		S S
		extmute			bool	true/false	External Mute Control enable flag	Enable/disable external mute control for this output	S S
		vol			float (32-bit) number	-96.0dB..12.0dB	Volume	For mode = s, value type will be array of left & right channels	S S
			up		float (32-bit) number	> 0.0dB	Increase volume by specified value		S N
			down		float (32-bit) number	> 0.0dB	Decrease volume by specified value		S N
		status			object		Input Status information		- -
		filterX			signed 8-bit number	-96.0dB..12.0dB	Level out meter status		N S
					object		Filter X where X = 1..numfilterout		- -
			id		unsigned 8-bit number	1..numfilter	Filter ID index		N S
			enable		bool	true/false	Enable flag		S S
			type		string	hp, lp	Filter type: hi-pass, all-pass	Two byte string	S S
			freq		unsigned 16-bit number	50Hz..20kHz	Cut-off frequency		S S
			gain		float (32-bit) number	-15.0dB..15.0dB	Gain (cut / boost)		S S
			family		char	b, s, l	Filter family: butterworth, besse, linkwitz-riley		S S

SERIAL COMMAND PROTOCOL (CONT)

Section	Group	Param	Sub	Ssub	Value Type	Value Range	Description	Comment	Operation Permission
		compressor	slope		unsigned 8-bit number	6dB..24dB	Slope of iter in 6dB steps		S
			enable		bool	true/false	Compressor block enable flag		-
			threshold		float (32-bit) number	-89.9dB..5.9dB	Threshold activation level		S
			makeup		float (32-bit) number	-30.0dB..30.0dB	Make-up compensation gain level (post compressor)		S
			ratio		float (32-bit) number	1.0..∞	Compression Ratio (X:1)	Compressor generally < 20:1. Limiter generally ∞:1	S
			knee		unsigned 8-bit number	0dB..48dB	Knee width (in steps of 6dB)	Limiter has hard knee (0dB width)	S
			attack		unsigned 16-bit number	1ms..9s	Attack time (ms)	Limiter has zero attack time	S
			hold		unsigned 16-bit number	0ms..2s	Hold Time (ms)		S
			release		unsigned 16-bit number	1ms..9s	Release Times (ms)		S
			status		object		Status information		-
				level1	unsigned 8-bit number	-96.0dB..12.0dB	Level in meter status		N
				level0	unsigned 8-bit number	-96.0dB..12.0dB	Level out meter status		N
		amp			object		Amplifier Status Information		-
			status		object		Status Information		-
			tempwarm		bool	true/false	Thermal warm level warning		N
			tempnot		bool	true/false	Thermal hot level warning		N
			standby		bool	true/false	Standby Status		N
			overtemp		bool	true/false	Overtemperature Shutdown status		N
			overload		bool	true/false	Overload Shutdown status		N
			fault		bool	true/false	Startup fault status		N
			reset		bool	true/false	Reset status		N
			mute		bool	true/false	Mute status		N
			astatus		array[], bool		Status information	NB: this is an array, not an object	-
			...				As per status		-
presetX					Object		Preset Audio Processing Section where X = 1..numpreset		-
	...						as per active section above, no status fields		-

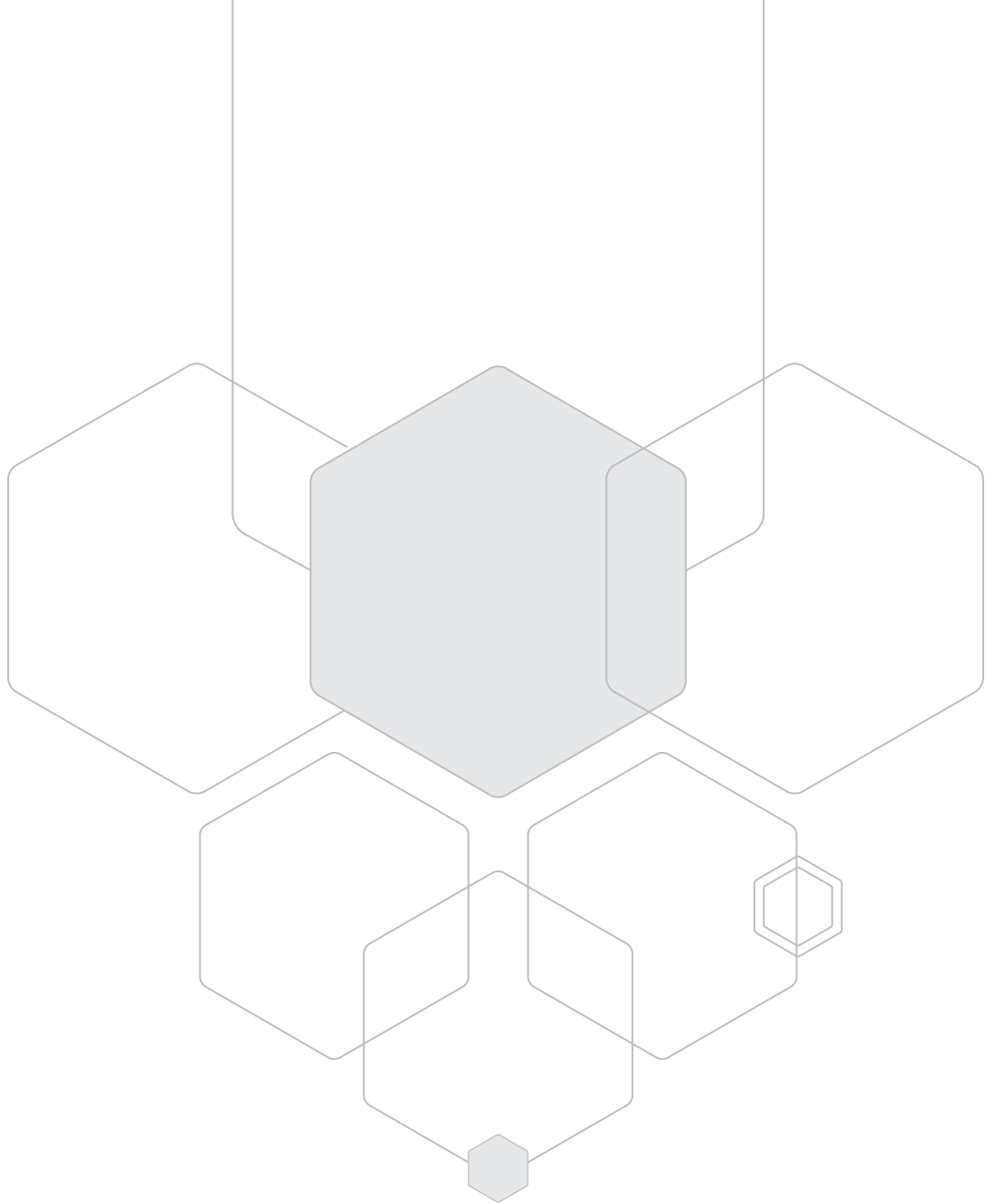

ENGINEERED BY AUSTRALIAN MONITOR
Address: 1 Clyde St, Silverwater NSW 2128 Australia.
Website: www.australianmonitor.com.au
International enquiries email: international@australianmonitor.com.au
ABN 35 007 573 417