

CELEBRATING
45
YEARS
OF AUDIO
INNOVATION

SRP 501/215 SRP 601/216

2 way active monitor | owners manual

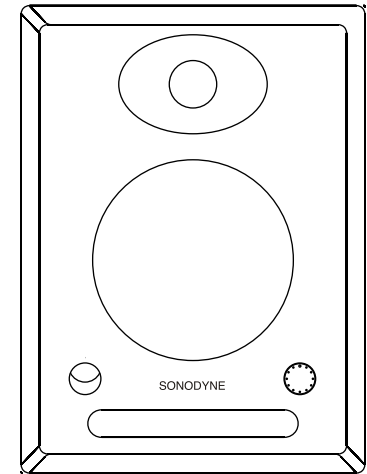
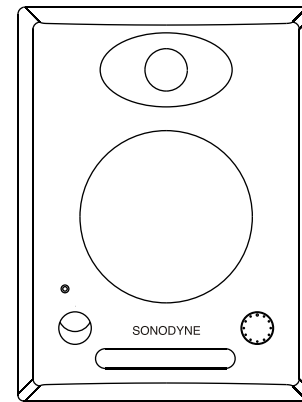

 **SONODYNE**[®]

A product of the Mukherjee Innovation Centre

Manufactured by Sonodyne Electronics Co Pvt Ltd, 98 NB Block E New Alipore, Kolkata 700053, INDIA
Tel: +91 33 23990418, 23983406; Fax: +91 33 23967243; E-mail: response@sonodyne.com
Please visit us at www.sonodyne.com

 **SONODYNE**[®]
REFERENCE SERIES

INTRODUCTION

Congratulations on your purchase of the SRP501/215/601/216 near field active studio monitor. The SRP501/215/601/216 has all the makings of a truthful reference device. The high grade transducers, the aluminum die cast rigid enclosure, the active amplification, the on board EQ, among others, result in sound that is neutral and transparent. You may thus depend on the SRP to accurately meet your professional monitoring needs.

SAFETY



The lightning flash with an arrowhead symbol is intended to warn the user that there is uninsulated (dangerous) voltage inside the unit.



The exclamation mark within an equilateral triangle symbol is intended to alert the user of presence of important operating instructions in the owner's manual accompanying the product.

IMPORTANT SAFETY INSTRUCTIONS

1. The unit should be connected only to a wall outlet providing the correct mains voltage and frequency as printed on the product.
2. Connect the unit to the mains only with the mains cable supplied with the unit.
3. Ensure that the wall outlet is properly earthed, that is, the earth must be connected to a earth bus-bar which connects to other audio equipments and is not shared by noisy equipments like computers, air-conditioners, lighting appliances etc. The earth connection must be checked and certified by a qualified electrical engineer.
4. Do not place the unit on an unstable surface that may topple and cause the unit to fall, thereby causing injury to the user or other people.
5. Do not place the unit outdoors where it may be exposed to strong sunlight, rain or moisture. Do not place it near a water body or sprinkler.
6. Do not cover the unit or block the ventilation holes on the back which may cause it to heat up.
7. Do not place the unit near heat radiating items like stoves, radiator etc.
8. Do not allow liquid or any chemical to spill on or into the product.
9. Do not allow the mains cord to be trodden or pinched particularly at the wall outlets or at the point of entry of the cord into the unit.
10. Do not open the unit or attempt to service it yourself. There is no user-serviceable part inside. Refer servicing to qualified service personnel only.
11. Replace only with the same type and rating of fuse as printed on the product.
12. Do not overload wall outlets that provide power to this unit.

UNPACKING

While removing the units from the carton, please do not hold the speaker's front. The high frequency transducer is located near the top of the cabinet, on the front baffle; you may accidentally damage the transducer.

The best way to safely unpack the monitors is to open the top of the carton, keep the EP filler piece on, turn the entire carton upside down and pull off the carton. Then remove the filler pieces and the protective cloth.

SYSTEM DESCRIPTION	2-way active monitor
TRANSDUCER COMPLEMENTS	LF: 6" PP cone woofer HF: 26mm silk-dome neodymium magnet tweeter
ENCLOSURE TYPE	Vented, through front-firing aerodynamic port
ENCLOSURE MATERIAL	Die-cast aluminium
OVERALL FREQUENCY RESPONSE	65 Hz ~ 20 kHz, (± 3 dB)
USABLE FREQUENCY RESPONSE	55 Hz ~ 22 kHz, (± 10 dB)
MAX SPL, HALF SPACE	107 dB
CROSSOVER FREQUENCY	2.5 kHz
AMPLIFIER POWER BEFORE CLIPPING	LF: 80 W HF: 50 W
TYPE	CLASS AB
S/N RATIO (AT UNITY GAIN)	> 90 dB, referred to full output
THD AT RATED POWER	< 0.04 %
CMRR	> 65 dB
INPUT LEVEL FOR 90 dB SPL AT 1M	0 dBu
INPUT IMPEDANCE	22 kOhm
CONTROLS, I/O	
INPUT	Fully balanced XLR & TRS socket
GAIN CONTROL RANGE	-70 dB to +6 dB
BASS TILT	-2 dB, -4 dB, -6 dB @ 80 Hz
TREBLE TILT	-2 dB @ 15 kHz
BASS ROLL-OFF	80 Hz, 6 dB/octave
CONTROLS : FRONT	Power Switch, Gain Control,
CONTROLS : REAR	4 DIP switches for bass/ treble tilts & bass roll-off
INDICATOR	Power ON /OFF
GENERAL	
POWER REQUIREMENT	230 V AC, ± 10 %, 50 Hz
POWER CONSUMPTION	160W Max.
PROTECTION	Over current, Overheat, RFI, Switch on/ off
FINISH	Black powder coated
MECHANICAL DIMENSIONS (WxHxD) mm	250 x 340 x 240
NET WEIGHT	11.9 kg
INSERTS FOR MOUNTING	2 x M6 inserts on rear, 4 x M6 inserts on bottom,
WALL MOUNT BRACKET	SRP WB 2

All specifications are subject to change due to continuous improvements

SRP 501/215 Specifications

SYSTEM DESCRIPTION	2-way active monitor
TRANSDUCER COMPLEMENTS	LF: 5" woofer PP cone HF: 26mm silk-dome neodymium magnet tweeter
ENCLOSURE TYPE	Vented, through front-firing aerodynamic port
ENCLOSURE MATERIAL	Die-cast aluminium
OVERALL FREQUENCY RESPONSE	75 Hz ~ 20 kHz, (± 3 dB)
USABLE FREQUENCY RESPONSE	65 Hz ~ 22 kHz, (± 10 dB)
MAX SPL, HALF SPACE	104 dB
CROSSOVER FREQUENCY	2.5 kHz
AMPLIFIER POWER BEFORE CLIPPING	LF: 45 W HF: 45 W
TYPE	CLASS AB
S/N RATIO (AT UNITY GAIN)	> 90 dB, referred to full output
THD AT RATED POWER	< 0.04 %
CMRR	> 65 dB
INPUT LEVEL FOR 90 dB SPL AT 1M	0 dBu
INPUT IMPEDANCE	22 kOhm
CONTROLS, I/O	
INPUT	Fully balanced XLR & TRS socket
GAIN CONTROL RANGE	-70 dB to +6 dB
BASS TILT	-2 dB, -4 dB, -6 dB @ 80 Hz
TREBLE TILT	-2 dB @ 15 kHz
BASS ROLL-OFF	100 Hz, 6 dB/octave
CONTROLS : FRONT	Power Switch, Gain Control
CONTROLS : REAR	4 DIP switches for bass/ treble tilts & bass roll-off
INDICATOR	Power ON /OFF
GENERAL	
POWER REQUIREMENT	230 V AC, ± 10 % , 50 Hz
POWER CONSUMPTION	90W Max.
PROTECTION	Over current, Overheat , RFI, Switch on/ off
FINISH	Black powder coated
MECHANICAL DIMENSIONS (WxHxD)	210 mm x 279 mm x 181 mm
NET WEIGHT	6.8 kg
INSERTS FOR MOUNTING	2 x M6 inserts on rear, 4 x M6 inserts on bottom
WALL MOUNT BRACKET	SRP WB 2

All specifications are subject to change due to continuous improvements

Fig. 1

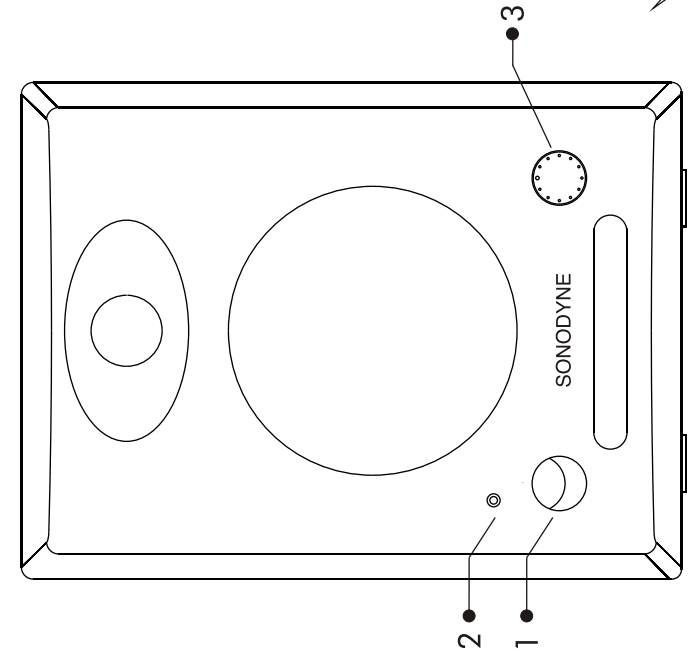

SRP 501/ 215/SRP 601/216

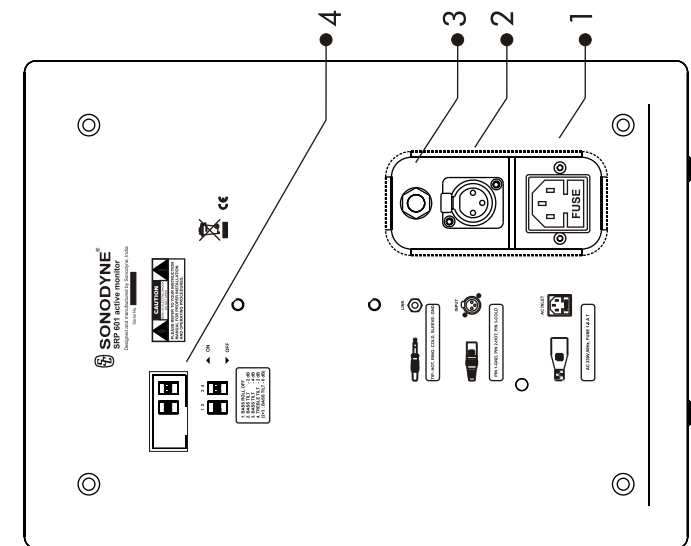

SRP 501/ 215/SRP 601/216

FRONT PANEL

1. **POWER SWITCH:** This switch is used to turn power ON/OFF
2. **POWER INDICATOR:** This lights up when power is ON
3. **GAIN:** This control adjusts the gain of the SRP 501/ 215/ 601/216. At the extreme anti-clockwise position, the gain is $-∞$, which signifies mute, and at the extreme clockwise position it is $+6$ dB. At the center position the gain is 0 dB. To help you identify the center position, a mechanical detent is provided in the control. With the gain control in the center position, an input signal equal to the rated sensitivity of the product will produce an SPL of 90dB at 1 meter distance.

REAR PANEL (refer to Fig. 1 on page 2)

1. **AC SOCKET** This is a fused 3-pin IEC AC receptacle for connecting to a wall outlet with the cable supplied. Ensure that the wall outlet is properly earthed, that is, the earth must be connected to a earth bus-bar which connects to other audio equipments and is not shared by noisy equipments like computers, air-conditioners, lighting appliances etc. The earth connection is also required in the interests of your own safety, should any fault occur. Please check that the wall outlet is capable of providing the current requirement of the product, printed on the back panel near the IEC AC socket.
2. **BALANCED INPUT:** This is a fully balanced XLR input socket. Pin connections are 1: ground, 2: hot or positive, 3: cold or negative.
3. **LINK:** This TRS socket is wired in parallel to the input socket and is used for looping the signal to another product. Pin connections are tip- positive, ring –negative, and sleeve-ground.
4. **ROOM COMPENSATION switches**
BASS ROLL-OFF: Switch 1 when ON introduces a low frequency roll-off into the response curve.
For many applications, removal of deep bass content allows you to raise the overall output level, permitting LOUD mixing. But, keep in mind that removing deep bass content from monitors may actually result in an inaccurate bass reproduction.
BASS TILTS: Switches 2 & 3 when ON activate a filter @ 80 Hz, to reduce the low frequency output by 2 dB & 4 dB respectively. Engaging both switches produces a 6 dB roll-off.

- SYMPTOM:** Device remains 'OFF'
- Make sure that the power cord is securely seated in the IEC socket and plugged all the way into the AC outlet.
 - Make sure that the AC outlet is live (check with tester).
 - Remove power cord and check the Fuse. If blown, then replace with exact type and rating.

- SYMPTOM:** Device is 'ON' but no audio output
- Is the master level control on the front panel turned up?
 - Is the signal source turned up? Make sure that the signal level from the device preceding the SRP is high enough to match the Input sensitivity (Gain control on rear panel).
 - If either stereo pair is not producing sound, then switch the signal around. If the problem also switches sides, the problem is not the monitor. It could be a bad signal cable, or no signal from the mixer.

- SYMPTOM:** Distorted sound
- Ensure secure connectivity of the XLR.
 - Reduce signal level at mixer or reduce gain control of SRP at rear panel.
 - Monitor the signal with headphones. Distorted sound in headphones indicate that the problem lies in the signal source.

- SYMPTOM:** Noise / Hum / Line interference
- Proper signal wiring between the mixer and the monitor eliminates the hum, buzz and all sorts of crackling noises. Make sure all connections are secure.
 - If unbalanced sources are used, make sure the cable run is not too long resulting in hum pick-up problems. Improper cabling will result in unsatisfactory audio reproduction. (please refer to XLR pin connections under Controls and Features on page 3)
 - If a CATV cable is connected to the system, and a persistent mains hum occurs, disconnect it. If the hum goes away call the cable operator to check for proper cable grounding methods. Using BALUN transformers (1:1, isolated type) might solve the problem.
 - Make sure that the signal cable is not routed near AC cables.
 - If a light dimmer or triac-based device exists on the same AC circuit as the monitor, buzzing noises may occur. AC Line filters may eliminate the problem.

PLACEMENT OF SPEAKERS

Distance from walls While placing speakers, make sure that they are at least 40 cm away from any reflecting surface. This will help minimise bumps in the low-frequency response due to reflections, and also ensure that the rear-mounting port is unobstructed. It is also required to ensure that the heat sinks at the back have adequate ventilation, for uninterrupted operation.

MOUNTING OF MONITORS

The speakers may be mounted on brackets fixed to wall, or on stands. The SRP 501/215 and SRP 601/216 have 2 x M6 threaded metal inserts on the back, for fixing to a wall bracket. Also provided are 4 x M4 threaded inserts on the bottom, for all the 2 models. The position of inserts on the back and the bottom are shown in the figure

SRP 501/215

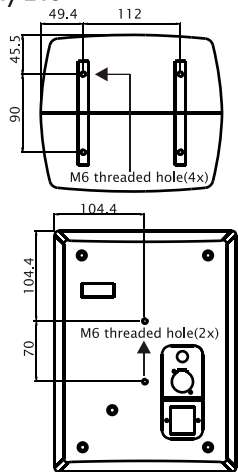

SRP 601/216

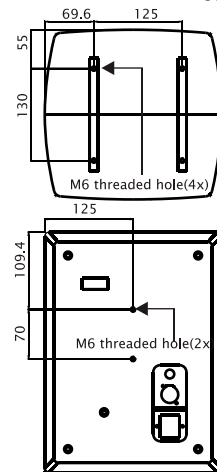

POSITIONING OF MONITORS

To get the flattest response, place the monitors vertically such that the center of the tweeter is roughly at ear level. If the tweeter level is lower than the ear level, there will be a loss in high frequencies, depending on how much lower the tweeter is, below ear-level. You can compensate this to some extent with the help of the High shelving switch (please see under 1). If the tweeter is higher than ear level, then, in addition to loss in high frequencies, there will be a dip around 2kHz.

These functions can be used to compensate for the build-up of low frequencies that occur when the speakers are placed near walls or corners, or on the workbench surfaces. When the speakers are at a free-standing position, away from walls or workbenches, turn these speakers to OFF position.

ROOM COMPENSATION (HF) (HF TILTS): Switch 4 introduces a high frequency response shelf cut of 2 dB above 4 kHz. This feature can be used if the testing room is 'fairly live' or the listening position is close to the speakers. But it is generally not used for applications in 'dead' rooms.

After you've studied the Pm's rear panel switches, do not hesitate to experiment with the settings and also monitor placement to get the best results.

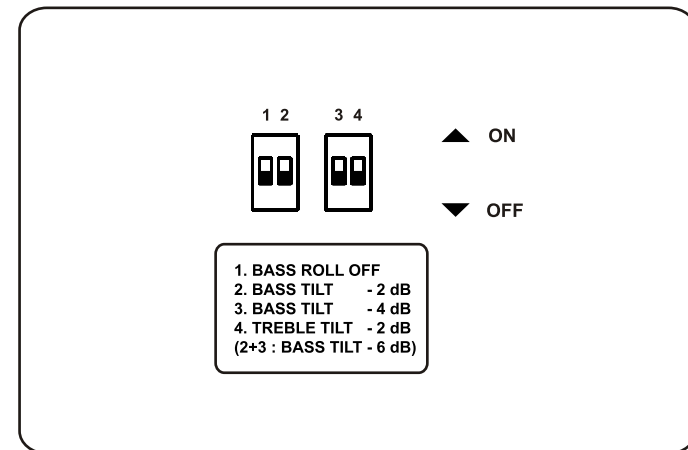

The effects of the plots are:

SRP 501/215: Bass tilt & Treble tilt: Fig 3
Bass Roll off: Fig 4

SRP 601/216: Bass tilt & Treble tilt: Fig 5
Bass Roll off: Fig 6

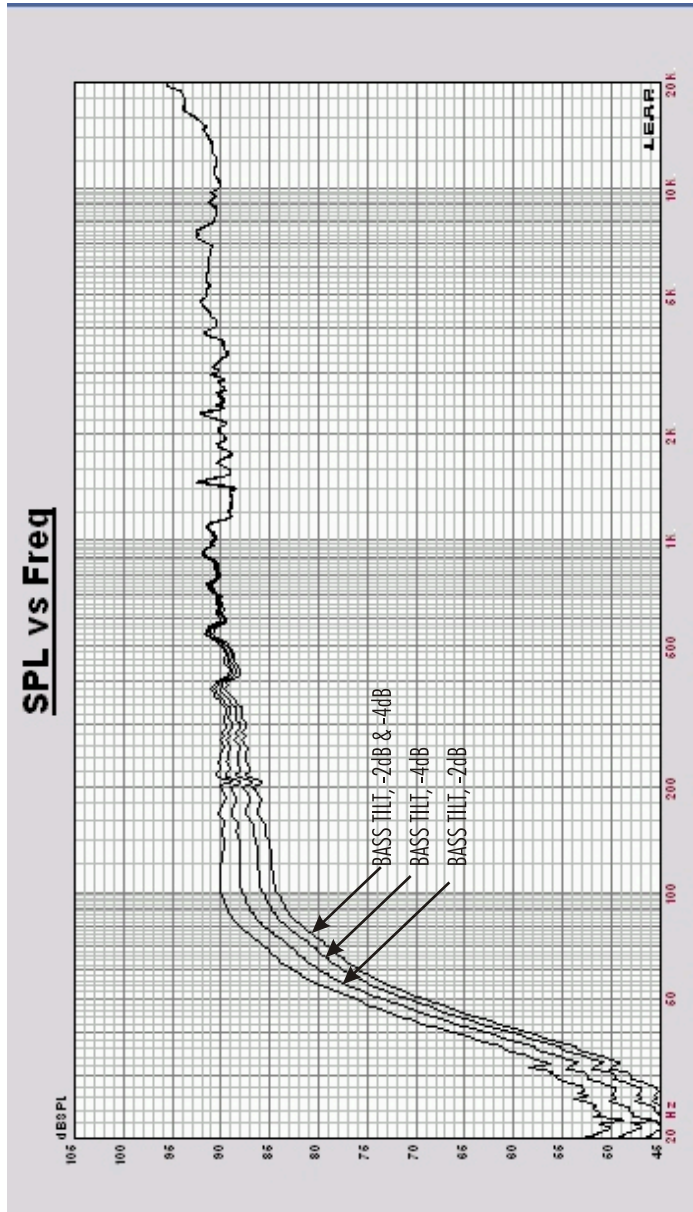

Fig. 3

INSTALLATION

ROOM PLACEMENT: The SRP has a wide variety of placement options. Shown in Fig. 7 is a typical stereo setup for near field monitoring. Shown in Fig. 8 is a typical 5 channel setup.

The monitors should be angled to directly face the listener. The center of the high frequency transducer should be on-axis with the ear level of the listener.

The low frequency compensation settings can be used when speakers are placed in close proximity to walls, corners and work surfaces.

LISTENING DISTANCE: The common listening position at mixing positions is generally 1 to 1.5 m for near field applications. The stereo listening angle is more a matter of personal preference, but we recommend the angle should be around 60° as shown in Fig. 7 & 8

MOUNTING OPTIONS: For mounting the speaker on a wall 4 inserts are provided on the base as shown in Fig 11

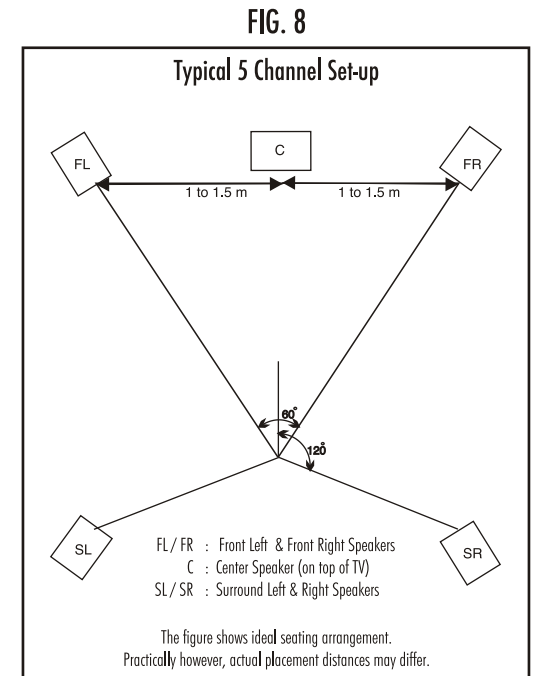
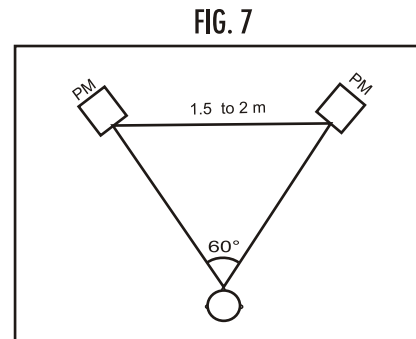

OPERATION

- Connect the line level monitor signal from your mixer (or any other source) to the signal input on the SRP using balanced cables (3 pin XLR).
- Connect the supplied AC power cord to the IEC socket at rear panel.
- Keep the power switch at OFF position.
- Switch on your mixer, but keep the master level control at minimum.
- Switch on SRP. The blue power LED will light up. Ensure that the Input Sensitivity (Gain control at the rear panel) is set to 0 dB
- Adjust the master volume on your mixer to get the desired listening level.

Note

Your SRPs' achieve their best bass response in a room that is optimized for bass reproduction. Factors such as room shape and volume, absence of acoustical treatment can prove to be a bane for optimal sound reproduction from the SRP . Therefore we have provided some compensation controls which you can use to optimize the frequency response of the speakers for any particular room. For the effect of these 'tilts' please refer to Fig: 3-6 .

MAINTENANCE

No user serviceable parts inside the unit. All maintenance and repair work to be undertaken by qualified personnel only.

SRP 501/215

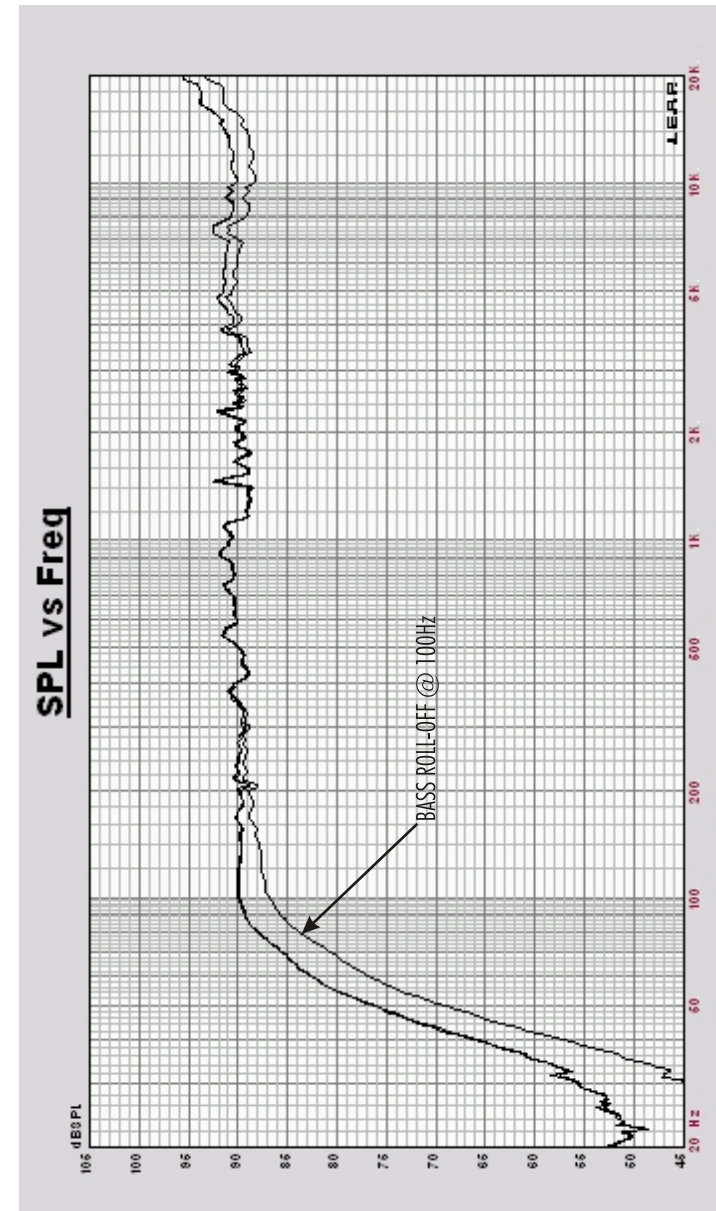

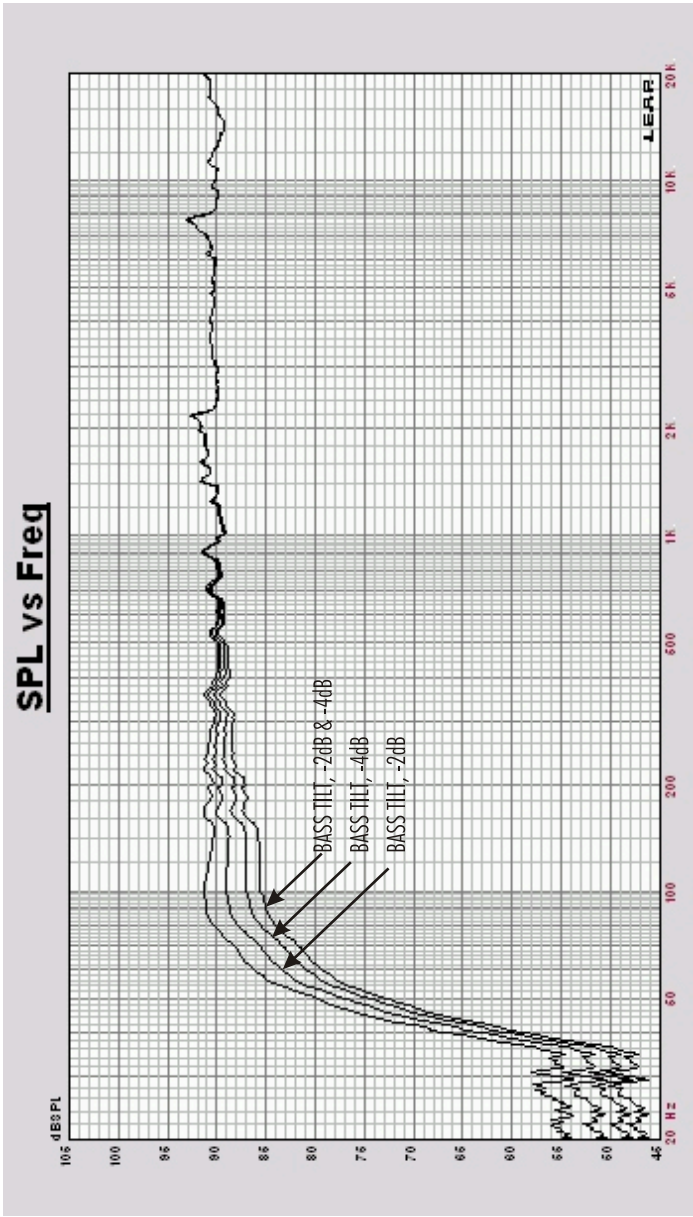

Fig. 6

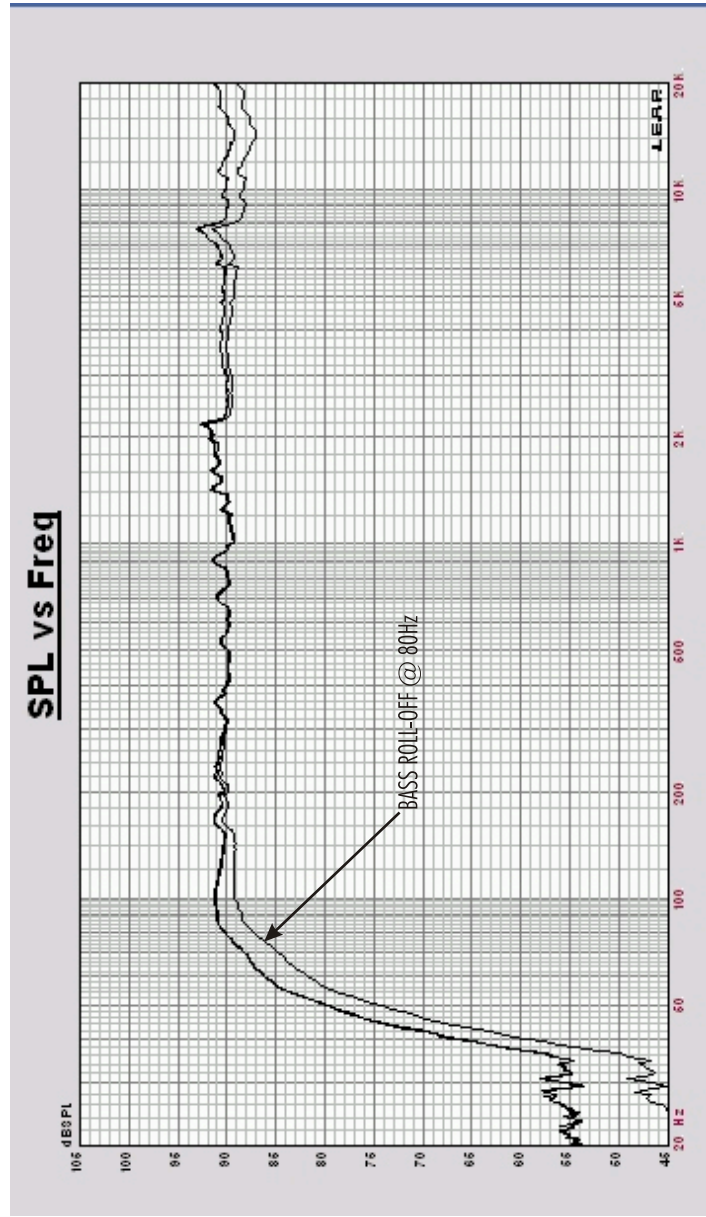

Fig. 5