

SONODYNE[®]

SPA 1100 SERIES

SPA 1108/1110/1112/1115

2 way professional speakers | owners manual

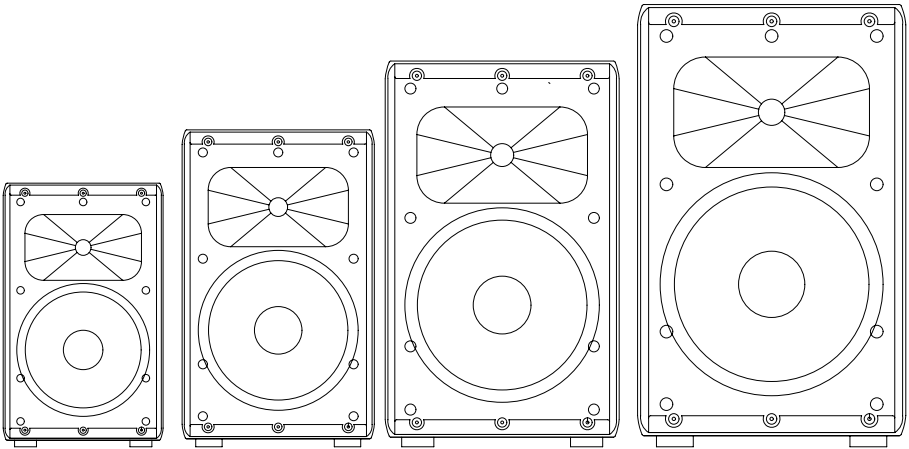

MADE IN INDIA
since 1970

SAFETY INSTRUCTIONS • UNPACKING

Congratulations on your purchase of the SPA series, 2-way professional speaker. It can be used for live sound reinforcement, and permanent installation.

IMPORTANT SAFETY INSTRUCTIONS

1. Do not place the unit on an unstable surface that may topple and cause the unit to fall, thereby causing injury to the user or other people.
2. Do not place the unit outdoors where it may be exposed to strong sunlight, rain or moisture. Do not place it near a water body or sprinkler.
3. Do not place the unit near heat radiating items like stoves, radiator etc.
4. Do not allow liquid or any chemical to spill on or into the product.
5. Do not open the unit or attempt to service it yourself. There is no user-serviceable part inside. Refer servicing to qualified service personnel only.
6. Install the unit by following instructions provided by the manufacturer.

UNPACKING

To unpack the unit, open the carton by cutting along the edge of the flaps. Push the flaps wide open. Fold any one flap and tilt the carton on this edge taking care that the flap stays open. Gently turn the carton upside down so that all the 4 flaps stay open and spread out, and the unit comes to rest on the EPE buffer. You may need someone to help you with this. Next lift the carton from the unit. Remove the EPE buffer on the bottom of the unit, facing you.

Carefully lift the unit from the EPE buffer on which it is resting, remove the protective cover and place it in its intended location.

MOUNTING

The SPA series can be flown, mounted on tripods, or fixed to wall with optional wall mounting bracket.

For flying, the SPA 1108P is equipped with 5 x M8 hanging points – 2 on the top, 2 on the bottom and 1 at the back. The other models SPA 1110P, SPA 1112P, SPA 1115P have 6 x M8 hanging points – 3 on the top, 2 on the bottom and 1 at the back.

For tripod mounting, there is a twin 35mm dia pole-mount socket on the bottom. Depth of both the sockets is 72mm. The pole near the back end is used when you want the speaker to be at 90° with respect to the pole-mounting surface, while the pole near the front end is meant to be used when you need a 5° tilt. The optional wall mounting bracket can be used to have both the options. Please see figures below:

FIG. 1

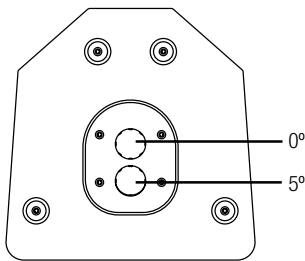
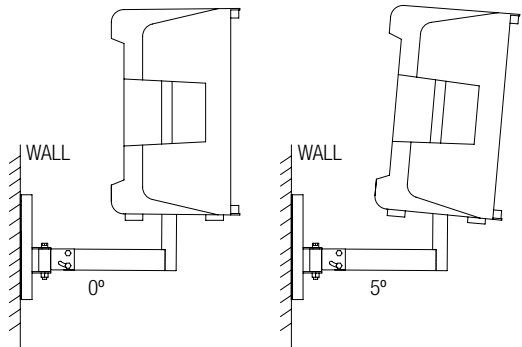

FIG. 2



A pair of handles for models SPA 1110, SPA 1112 and SPA 1115 allow the speakers to be lifted.

For the SPA 1008, one handle on the top is provided.

OPERATION

Connect the speaker output of your amplifier to the input connector which is a twist-lock type speaker connector. Pin connection are 1+ positive, 1- negative. There is another socket marked Link, which allows you to connect another speaker in parallel.

This is wired in parallel to the input connector and hence has the same pin connections.

SPECIFICATIONS

MODEL	SPA 1108	SPA 1110	SPA 1112	SPA 1115
DESCRIPTION	2 way passive speaker	2 way passive speaker	2 way passive speaker	2 way passive speaker
TRANSDUCERS	HF - 1 x 1" throat titanium dome compression driver, 1.35" dia voice coil LF - 1 x 8" woofer, 1.5" dia glass-fiber former voice coil	HF - 1 x 1" throat titanium dome compression driver, 1.35" dia voice coil LF - 1 x 10" woofer, 2.5" dia glass-fiber former voice coil	HF - 1 x 1" throat titanium dome compression driver, 1.75" dia voice coil LF - 1 x 12" woofer, 2.5" dia glass-fiber former voice coil	HF - 1 x 1" throat titanium dome compression driver, 1.75" dia voice coil LF - 1 x 15" woofer, 3" dia glass-fiber former voice coil
CABINET MATERIAL	Polypropylene	Polypropylene	Polypropylene	Polypropylene
FORM FACTOR	Trapezoidal, can be used as stage monitor	Trapezoidal, can be used as stage monitor	Trapezoidal, can be used as stage monitor	Trapezoidal, can be used as stage monitor
CABINET TOPOLOGY	Bass-reflex, through twin front-firing vents	Bass-reflex, through twin front-firing vents	Bass-reflex, through twin front-firing vents	Bass-reflex, through twin front-firing vents
POWER HANDLING				
CONTINUOUS	200W	300W	400W	500W
PROGRAM	400W	600W	800W	1000W
PEAK	800W	1200W	1600W	2000W
SENSITIVITY (1W/1M)	94dB	95dB	96dB	98dB
MAX SPL				
CONTINUOUS	117dB (half space)	120dB (half space)	122dB (half space)	125dB (half space)
PEAK	123dB (half space)	126dB (half space)	128dB (half space)	131dB (half space)
ACOUSTIC				
FREQ. RANGE (-10dB)	60Hz ~ 18kHz	55Hz ~ 18kHz	50Hz ~ 18kHz	50Hz ~ 18kHz
FREQ. RESP. (-3dB)	70Hz ~ 17kHz	65Hz ~ 17kHz	60Hz ~ 17kHz	60Hz ~ 17kHz
CROSSOVER FREQ.	2.5kHz	2.0kHz	1.5kHz	1.4kHz
NOMINAL IMPEDENCE	8Ω	8Ω	8Ω	8Ω
DIRECTIVITY H x V	90° x 50°	90° x 50°	90° x 50°	90° x 50°
SPK CONNECTOR	Twist-lock connector	Twist-lock connector	Twist-lock connector	Twist-lock connector
COLOUR	Black	Black	Black	Black
MOUNTING	2 x M8 inserts on top, 2 x M8 inserts on bottom and 1 x M8 insert at back, for flying. Twin 35 mm pole mounting. 4 x plastic legs	3 x M8 inserts on top, 2 x M8 inserts on bottom and 1 x M8 insert at back, for flying. Twin 35 mm pole mounting. 4 x plastic legs	3 x M8 inserts on top, 2 x M8 inserts on bottom and 1 x M8 insert at back, for flying. Twin 35 mm pole mounting. 4 x plastic legs	3 x M8 inserts on top, 2 x M8 inserts on bottom and 1 x M8 insert at back, for flying. Twin 35 mm pole mounting. 4 x plastic legs
DIMENSION HxWxD	420mm x 250mm x 255mm	500mm x 305mm x 310mm	610mm x 360mm x 350mm	700mm x 445mm x 375mm
NET WEIGHT	8.15kg	10.68kg	14.9kg	18.84kg
SHIPPING DIMENSION	490mm x 326mm x 326mm	576mm x 370mm x 365mm	682mm x 410mm x 415mm	788mm x 452mm x 512mm
GROSS WEIGHT	9.48kg	12.34kg	17kg	21.73kg

NOTE: Due to continuous improvements, all specifications are subject to change

SONODYNE

SONODYNE, India • H.O.: 98 NB Block E New Alipore, Kolkata 700053



sonodyneofficial



+91 9830855260



SonodyneMusic



response@sonodyne.com



sonodyneofficial



www.sonodyne.com