

INSTALLATION AND OPERATION MANUAL

ISP SERIES

POWER AMPLIFIERS IS2120P
IS2250P
IS4120P
IS4250P



IMPORTANT SAFETY INFORMATION

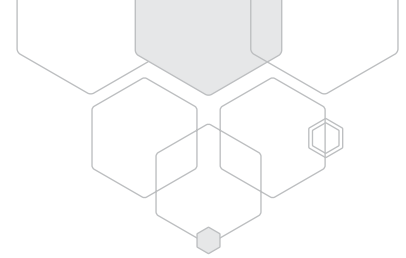

1. Read these instructions.
2. Keep these instructions.
3. Heed all warnings.
4. Follow all instructions.
5. Do not use this apparatus near water.
6. Clean only with dry cloth.
7. Do not block any ventilation openings. Install in accordance with the manufacturer's instructions.
8. Do not install near any heat sources such as radiators, heat registers, stoves, or other apparatus (including amplifiers) that produce heat.
9. Do not defeat the safety purpose of the polarized or grounding-type plug. A polarized plug has two blades with one wider than the other. A grounding type plug has two blades and a third grounding prong. The wide blade or the third prong are provided for your safety. If the provided plug does not fit into your outlet, consult an electrician for replacement of the obsolete outlet.
10. Protect the power cord from being walked on or pinched particularly at plugs, convenience receptacles, and the point where they exit from the apparatus.
11. Only use attachments/accessories specified by the manufacturer.
12. Use only with the cart, stand, tripod, bracket, or table specified by the manufacturer, or sold with the apparatus. When a cart is used, use caution when moving the cart/apparatus combination to avoid injury from tip-over.
13. Unplug this apparatus during lightning storms or when unused for long periods of time.
14. Refer all servicing to qualified service personnel. Servicing is required when the apparatus has been damaged in any way, such as power supply cord or plug is damaged, liquid has been spilled or objects have fallen into the apparatus, the apparatus has been exposed to rain or moisture, does not operate normally, or has been dropped.
15. This appliance must not be exposed to dripping or splashing water and no object filled with liquid such as vases shall be placed on the apparatus.
16. Plug this apparatus into the proper wall outlet and make the plug easily accessible for disconnection.
17. The mains plug is used to disconnect the device from the mains. It should remain readily available during intended use. In order to disconnect the apparatus from the mains completely, the mains plug should be disconnected from the mains socket outlet completely.
18. **WARNING:** To reduce the risk of fire or electric shock, do not expose this apparatus to rain or moisture.
19. An appliance with a protective earth terminal should be connected to a mains outlet with a protective earth connection.
20. The apparatus should be disconnected from the mains completely before connecting the speaker wiring. The copper wiring from the speaker outputs should not be allowed to come into direct contact with the device.



PRÉCAUTIONS DURANT UTILISATION

1. LISEZ ces instructions.
2. Tenez ces instructions.
3. Notez tous les avertissements.
4. Suivez toutes les avertissements.
5. N'utilisez pas ce produit près de l'eau (la piscine, la plage, le lac, etc.).
6. Nettoyez seulement avec une étoffe sèche.
7. Ne bloquez aucuns trous de ventilation. Installez en accord avec les instructions du fabricant.
8. N'installez près aucunes sources de chaleur comme radiateurs, registres de chaleur, fours ou les autres équipements (y compris ampli cateurs) qui produisent la chaleur.
9. Ne défaites pas le but de sécurité de la fiche polarisée ou base-type. Une fiche polarisée a deux tranchants avec un plus large que l'autre. Une fiche de base type a deux a deux tranchants et une troisième pointe de base, le tranchant large ou la troisième pointe est fourni pour votre sécurité. Si la fiche donnée ne conforme pas votre prise de contact, consultez un électricien pour remplacement de la prise de contact obsolète.
10. Protégez le cordon de secteur contre être marchée dessus ou pincez en particulier aux fiches, aux douilles de convenance, et au point où ils sortent de l'appareil.
11. Seulement utilisez attachements/accessoires spécifiés par le fabricant.
12. Utilisez seulement avec un chariot, un stand, un trépied, un support ou une table indiquée par le fabricant, ou vendue avec l'appareil. Quand un chariot est utilisé, faites attention en déplaçant la combinaison d'appareil/chariot pour éviter de se déséquilibrer.
13. Arrachez la fiche du dispositif durant éclair et orage ou quand pas utilisé pour longues périodes de temps.
14. Référez au personnel qualifié de service pour toutes réparations. La réparation est donnée quand le système a été endommagé à n'importe façon, par exemple un fil ou une fiche endommagé(e) de la source d'alimentation. Avoir été exposé à pluie ou humidité, n'opère pas normalement, ou avoir été tombé.
15. L'appareil ne doit pas être exposé aux écoulements ou aux éclaboussures et aucun objet ne contenant de liquide, tel qu'un vase, ne doit être placé sur l'objet.
16. Branchez l'appareil à une source appropriée et faire que la prise à débrancher soit facilement accessible.
17. La prise du secteur ne doit pas être obstruée ou doit être facilement accessible pendant son utilisation. Pour être complètement déconnecté de l'alimentation d'entrée, la prise doit être débranchée du secteur.
18. **AVERTISSEMENT:** Pour éviter le risque d'incendie ou de chocs électriques, ne pas exposer cet appareil à la pluie ou à l'humidité.
19. Un appareil avec la borne de terre de protection doit être connecté au secteur avec la connexion de terre de protection.
20. Assurez-vous que l'appareil est hors tension avant de connecter les hauts parleurs. Vérifiez que la sortie des enceintes soit protégées contre un contact physique. Respecter les polarités des terminaux ainsi que le câblage des enceintes pendant le fonctionnement afin d'assurer une utilisation sécurisée.



INTRODUCTION & CONTENTS

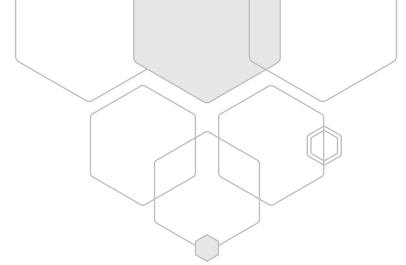

ISP SERIES

Congratulations on choosing Australian Monitor for your professional amplification requirements.

The design of our ISP series constant voltage power amplifiers embraces all the aspects of a well-designed amplifier. The visual design, mechanical, electrical and sonic parameters, along with our dedicated manufacturing process, have all been optimised to provide a professional tool that exhibits quality, reliability and longevity.

The ISP series power amplifiers are 1 unit 1.75" high, 19" wide, or 2 unit 3.5" high, 19" wide rack mountable units depending on the model.

Models are available in 2 and 4 channel versions. The ISP amplifier is fully controllable over an Ethernet interface which provides configuration and monitoring capabilities. An included DSP also allows control of the volume, matrix mixing, high/low/all pass filters, compressor/limiter and delay which feeds an efficient Class D amplifier to deliver 120W or 250W of output power per channel.

These amplifiers have been specifically designed to deliver their high power output with minimal distortion, and provide the critical degree of control required by your speakers.

Introduction	3
Features & Protection Features	4
Front Panel	5
Rear Panel	6
Installation & Setup	7
Basic Setup & Operation	16
Website User Interface	17
Maintenance, Fire Safety Compliance	21
Specifications	22

Revision 1.0: Aug 2019

WARNING

TO PREVENT FIRE OR SHOCK HAZARD, DO NOT USE THE PLUG WITH AN EXTENSION CORD, RECEPTACLE OR OTHER OUTLET UNLESS THE BLADES CAN BE FULLY INSERTED TO PREVENT BLADE EXPOSURE.

TO REDUCE THE RISK OF FIRE OR ELECTRIC SHOCK, DO NOT EXPOSE THIS APPLIANCE TO RAIN OR MOISTURE.

TO PREVENT ELECTRICAL SHOCK, MATCH WIDE BLADE PLUG TO WIDE SLOT & FULLY INSERT.

CAUTION

THESE SERVICING INSTRUCTIONS ARE FOR USE BY QUALIFIED SERVICE PERSONNEL ONLY. TO REDUCE THE RISK OF ELECTRIC SHOCK DO NOT PERFORM ANY SERVICING OTHER THAN THAT CONTAINED IN THE OPERATING INSTRUCTIONS UNLESS YOU ARE QUALIFIED TO DO SO.



The lightning flash with arrowhead symbol, within an equilateral triangle, is intended to alert the user to the presence of uninsulated "dangerous voltage" within the product's enclosure that may be of sufficient magnitude to constitute a risk of electric shock to persons.



WARNING
TO REDUCE THE RISK OF ELECTRIC SHOCK, DO NOT REMOVE COVER (OR BACK). NO USER SERVICEABLE PARTS INSIDE. REFER SERVICING TO QUALIFIED SERVICE PERSONNEL.



The exclamation point within an equilateral triangle is intended to alert the user to the presence of important operating and maintenance (servicing) instructions in the literature accompanying the appliance



For European Union countries: This symbol on the product or its packaging indicates that this product must not be disposed of with other waste. Instead, it is your responsibility to dispose of your waste equipment by handing it over to a designated collection point for the recycling of waste electrical and electronic equipment. Please contact your local authority for further details of your nearest designated collection point.

Rating plate and caution marking are marked on the back enclosure of the apparatus

FEATURES & PROTECTION FEATURES

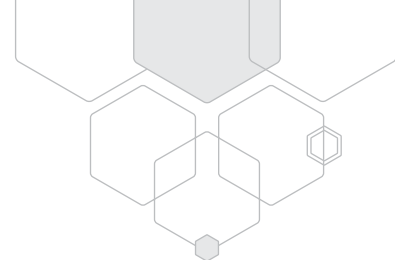

FEATURES

- IS2120P – 2x120W, IS2250P – 2x250W
- IS4120P – 4x120W, IS4250P – 4x250W
- 4Ω and 70V/100V outputs
- Class D amplifier technology
- Ethernet Control
- Embedded user interface via web browser
- DSP:
 - Volume control
 - Matrix Mixer
 - High/Low/All pass filters
 - 12 band parametric equaliser per channel
 - Compressor/Limiter
 - Delay up to 75m (220ms) per amplifier output
 - Audio level sense for standby/auto-wake
- Four software configurable external input/outputs
- API for third party integration
- Dante® 4In, 4Out expansion card option
- Analogue 4in expansion card option
- Rack mount size
- 1RU for 2 channel amplifiers
- 2RU for 4 channel amplifiers
- Fan cooled
- Universal switchmode PSU with PFC
- ErP (1275/2008/EC) Standby Compliant, less than 2W

PROTECTION FEATURES

- Clip protection
- Short-circuit protection
- Overload protection
- Thermal protection

ISP AMPLIFIER BLOCK DIAGRAM

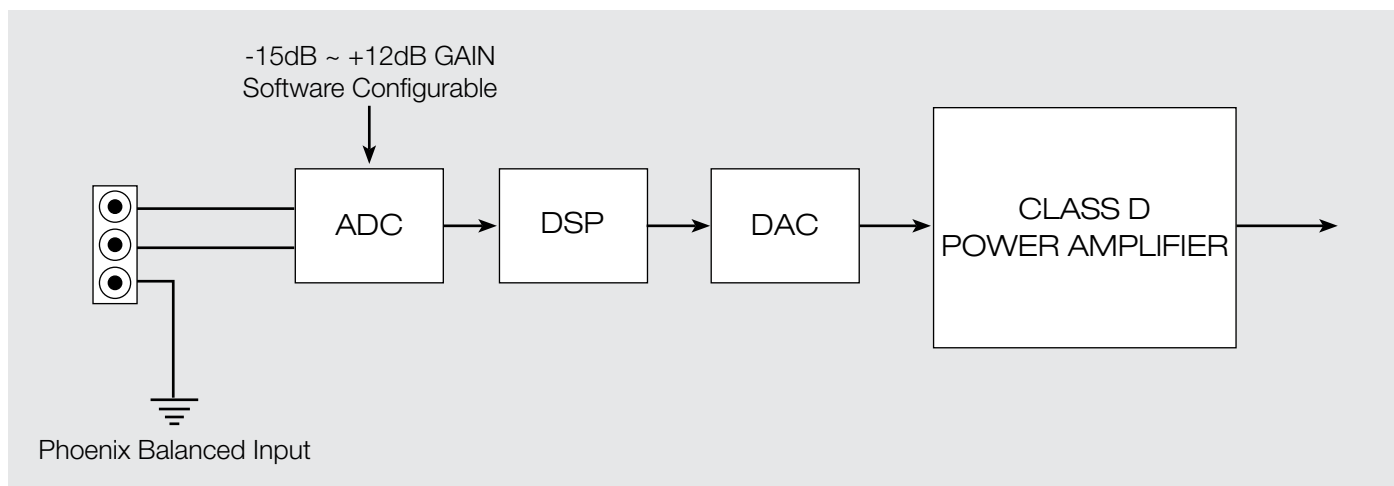

GLOSSARY

TERM	MEANING
DSP	Digital Signal Processor
USB	Universal Serial Bus
XLR	Audio electrical connector type
LED	Light Emitting Diode.
PHOENIX CONNECTOR	Terminal block connector type. Also known as a Euroblock.
DIP SWITCH	Dual in-line package switch. Used on the front and rear of the product to select various settings

FRONT PANEL

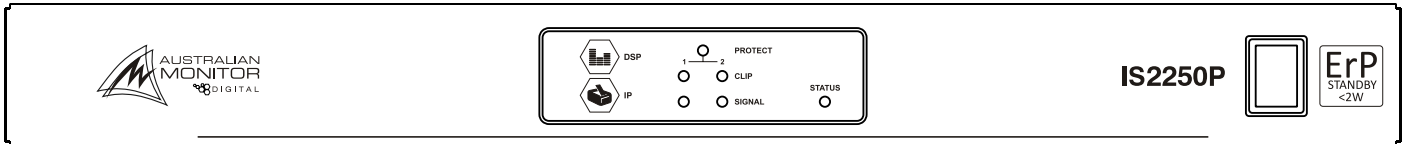
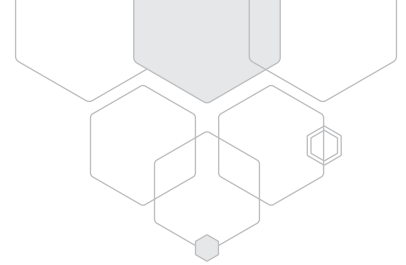

Front panel

IS2250P 1RU shown in above example. Similar arrangements for 2RU unit.

1 LED INDICATORS

STATUS INDICATOR

This blue LED indicates various states of the amplifier.

LED	MEANING	INDICATION
Blue On	Normal Operation	LED solid on. Indicates that device is powered and that no faults exist.
Blue Slow Flash	Standby Mode	Flash LED: On for 50ms, Off for 4s
Blue Flash	Error Mode	LED Off for 2s followed by a flash count of the error code, On for 300ms, Off for 300ms. Multiple errors will be indicated in consecutive error sequences. Refer to the Fault Finding section of this manual to fix any errors displayed.

PROTECT INDICATOR

The following table indicates the meaning of each protection mode

LED	MEANING
Yellow flashing	Amplifier temperature warm
Yellow on	Amplifier temperature hot
Red flashing	Amplifier over temperature*
Red on	Amplifier protect

See the Fault Finding section of this manual to fix any errors displayed.

* In the advent of a thermal overload, the internal operating temperature of the amplifier has exceeded a safe level of operation. The fan will continue to run and once the amplifier has cooled it will return to normal operation.

SIGNAL LED

The following table indicates the meaning of the signal LED

LED	MEANING
Green flashing	Audio signal mute
Green on	Audio signal present

OUTPUT CLIP INDICATOR

A red LED will illuminate when output signal clipping occurs.

2 POWER SWITCH

Press the switch to the up position to power the unit on. At start-up (turn-on), the input to the amplifier is muted for approximately two seconds.

REAR PANEL

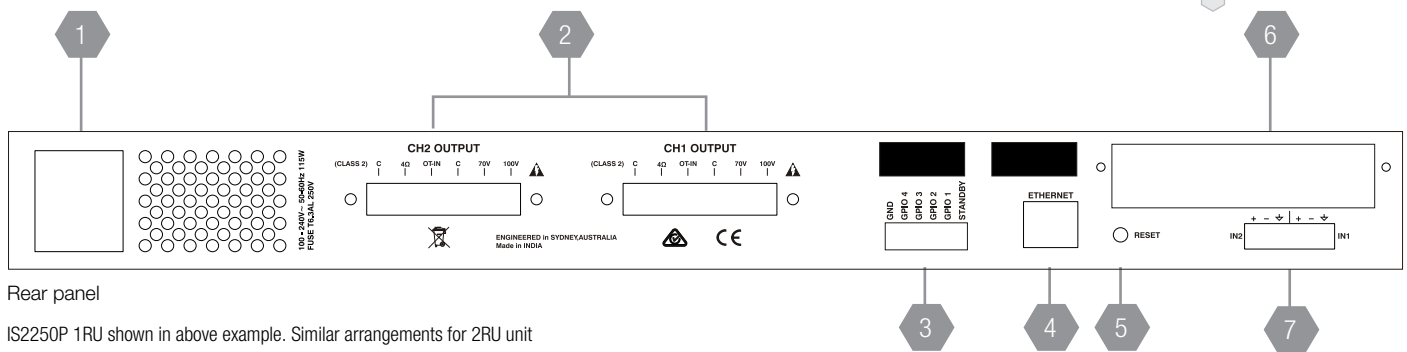

Rear panel

IS2250P 1RU shown in above example. Similar arrangements for 2RU unit

1 MAINS INPUT CONNECTOR

Your amplifier is fitted with a standard IEC 60320-C14 socket for mains connection. Use the mains cable supplied to power up the unit. NOTE: Your unit must always be earthed!

2 SPEAKER OUTPUTS

The class D amplifier output features 100V Line, 70V Line and 4Ω low impedance operation. Important: Remove the speaker connector link if operating the amplifier in 4Ω operation.

⚠ NOTE: Only one output type should be used at a time.
Consult the Output Wiring section of this manual for full details.

3 STANDBY AND GPIO PORTS

The standby and GPIO ports are used to control various states and functions of the amplifier. Consult the Standby and GPIO setup section of this manual for further details.

4 ETHERNET CONTROL

Ethernet control is used to communicate with the device over a LAN. The supported network speed is 100Base-T. Consult the Network setup section of this manual for further details.

5 RESET BUTTON

The reset button is used to reset the Network Configuration, security access or perform full factory reset. Consult the Reset Button section of the manual for further details.

6 EXPANSION BOARD INPUT

The device supports the following expansion cards:

- DM4x4 Dante Expansion Board (4 Inputs/ 4 Outputs)
- AM4 Analogue Expansion Board (4 Line level inputs)

Consult the Expansion Board installation section of this manual for detailed instructions on how to install the expansion board in the unit.

7 PHOENIX BALANCED INPUT

A balanced male 3-pin (3.81mm) Phoenix type connector is provided on each input channel. Consult the Balanced Input Wiring section of this manual for further detail of this control.

INSTALLATION & SETUP

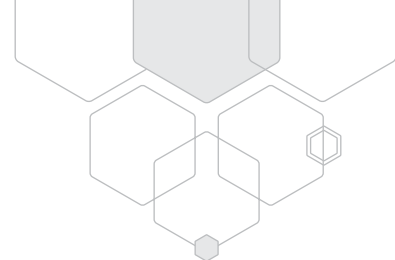

STANDBY AND GPIO SETUP

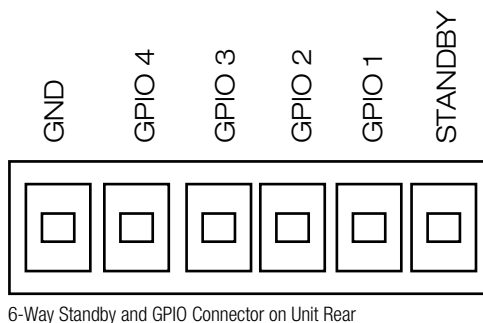

STANDBY

The standby functionality is activated using the supplied 6-way Phoenix connector which must be wired to close the contact on the standby pin on the rear of the ISP unit by connecting it to ground. See connection diagram listed below for a simple connection.

When in standby, the amplifier has entered a power saving mode where no audio will be present at the output. When the standby connection is removed the amplifier will restart the power amplifier and exit standby.

The amplifier ships with energy saving mode enabled and will enter auto standby if it detects a period of inactivity less than (-40dBV) for 30 minutes. The amplifier will exit standby mode when the signal level returns above -40dBV. The auto standby function can be disabled and the timeout period modified in the user interface.

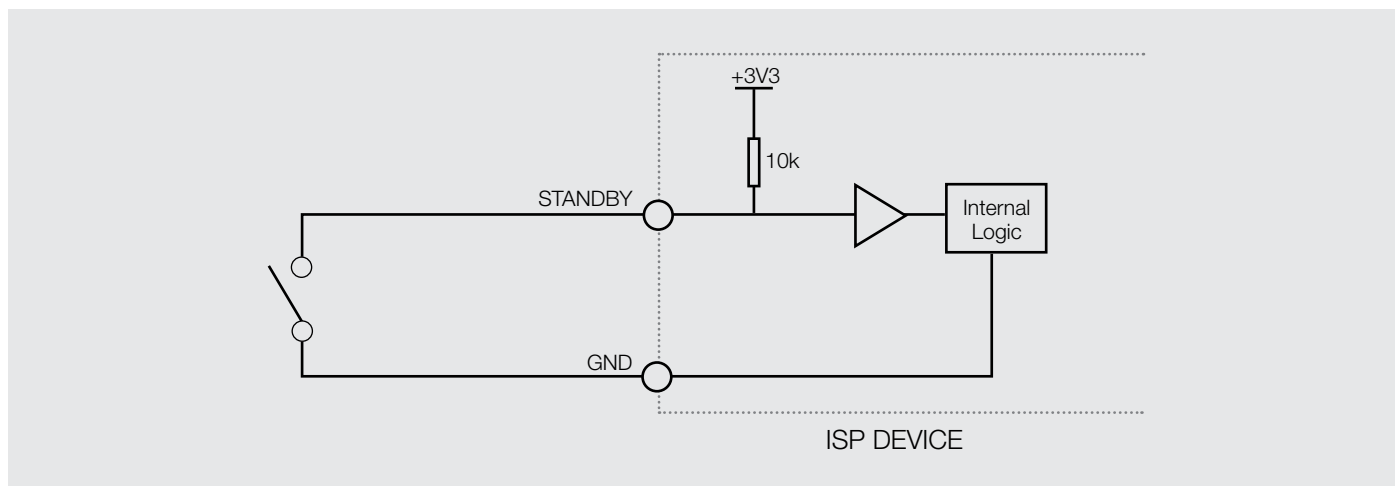

Switch closed = Standby active
Switch open = Standby not active

INSTALLATION & SETUP (CONT.)

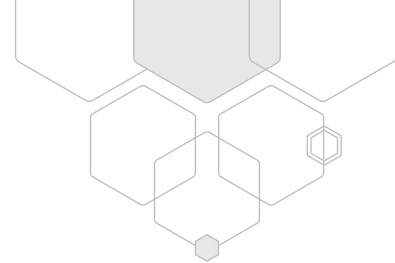

GPIO CONFIGURED AS INPUT:

Used for:

1. Mute output function
2. Recall preset function
3. Consult online manual for added functions

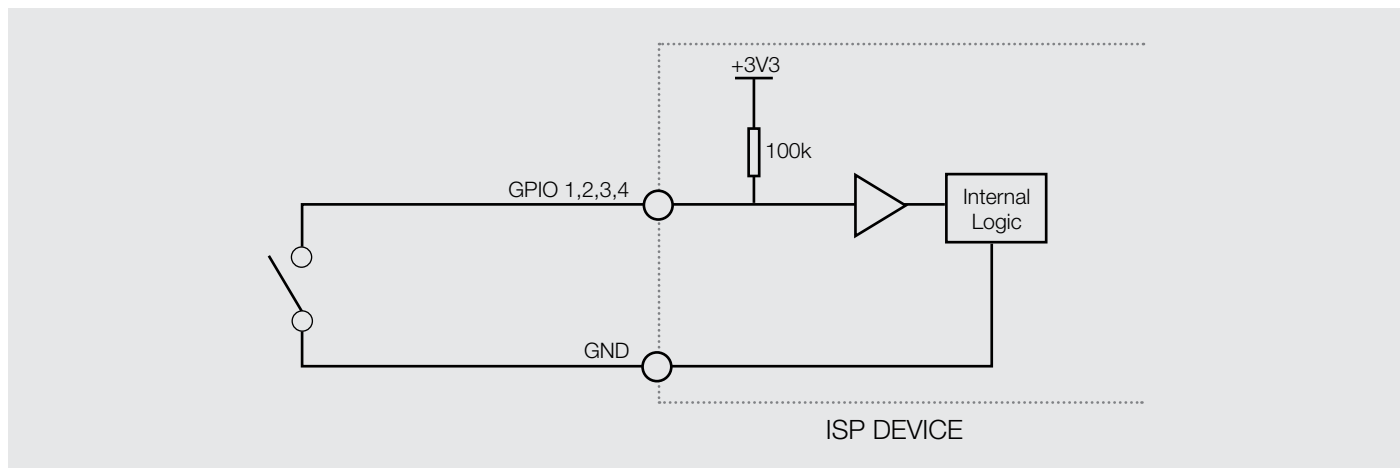

The GPIO's number, it's required function and its' active high or low signaling states are configured in webpage.

GPIO CONFIGURED AS ADC:

Used for:

1. VCA control of output volume
2. Consult online manual for added functions

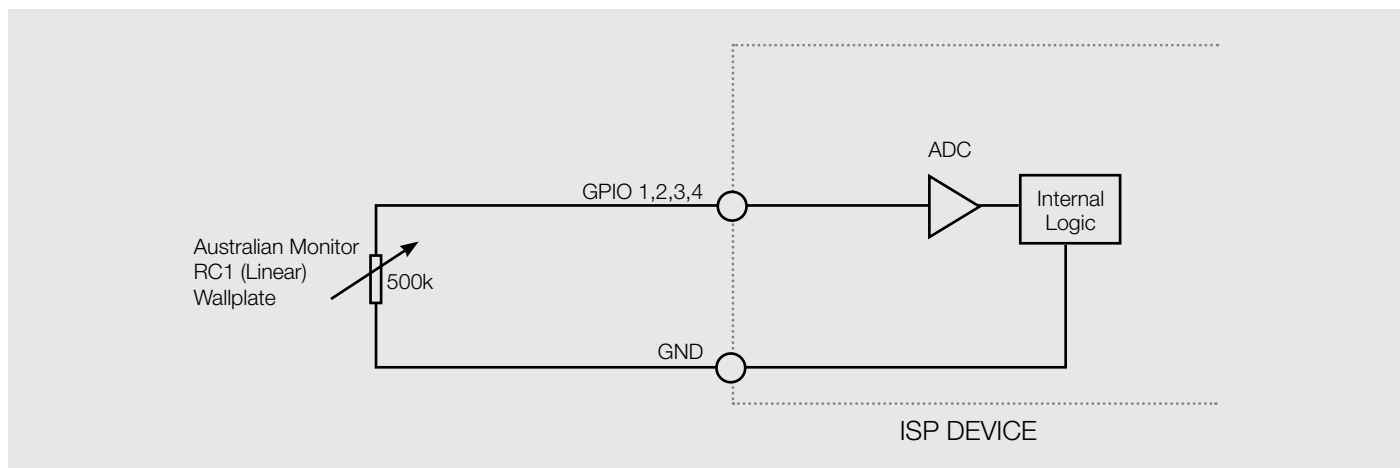

The GPIO's number, it's required function and its' active high or low signaling states are configured in webpage.

INSTALLATION & SETUP (CONT.)

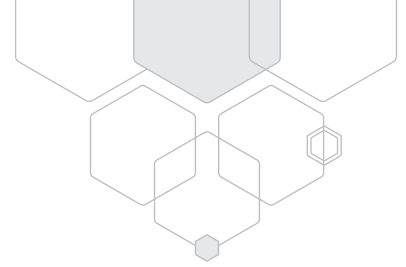

GPIO CONFIGURED AS OUTPUT WITH OPEN COLLECTOR:

Used for:

- | | |
|--|-------------------------------|
| 1. 1Hz Heartbeat Function | 2. Amplifier Fault Indication |
| 3. Amplifier Temperature Warm | 4. Amplifier Temperature Hot |
| 5. Consult online manual for added functions | |

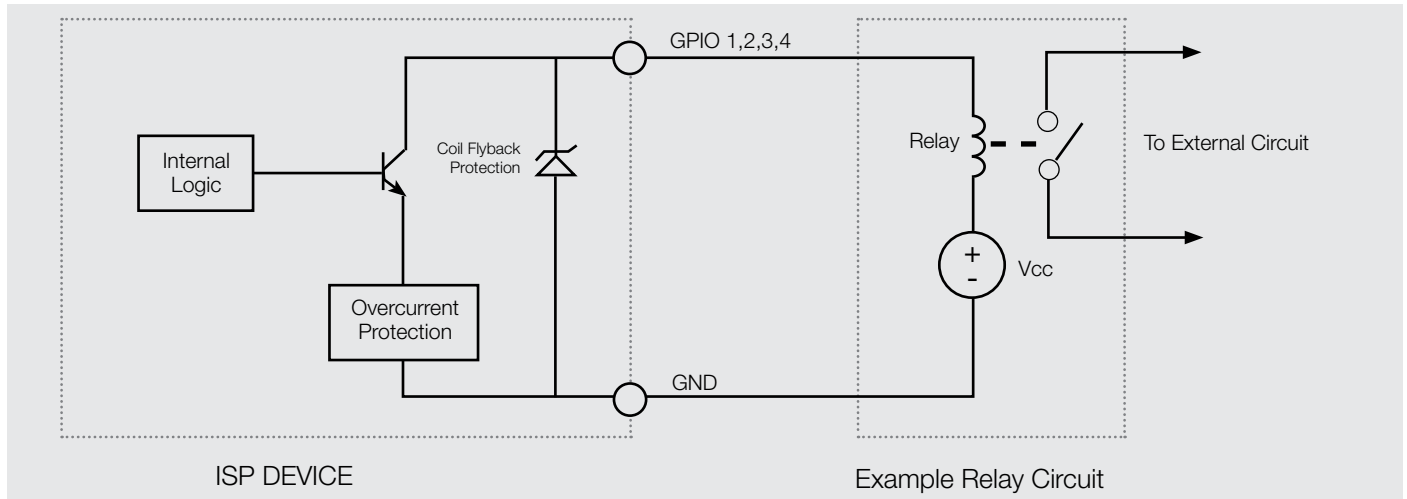

Max sinking current = 125mA
 Max Collector Emitter Voltage = 48V

The GPIO's number, it's required function and its' active high or low signaling states are configured in webpage.

GPIO CONFIGURED AS OUTPUT WITH OPEN COLLECTOR INTERNAL PULLUP:

Used for:

- | | |
|--|-------------------------------|
| 1. 1Hz Heartbeat Function | 2. Amplifier Fault Indication |
| 3. Amplifier Temperature Warm | 4. Amplifier Temperature Hot |
| 5. Consult online manual for added functions | |

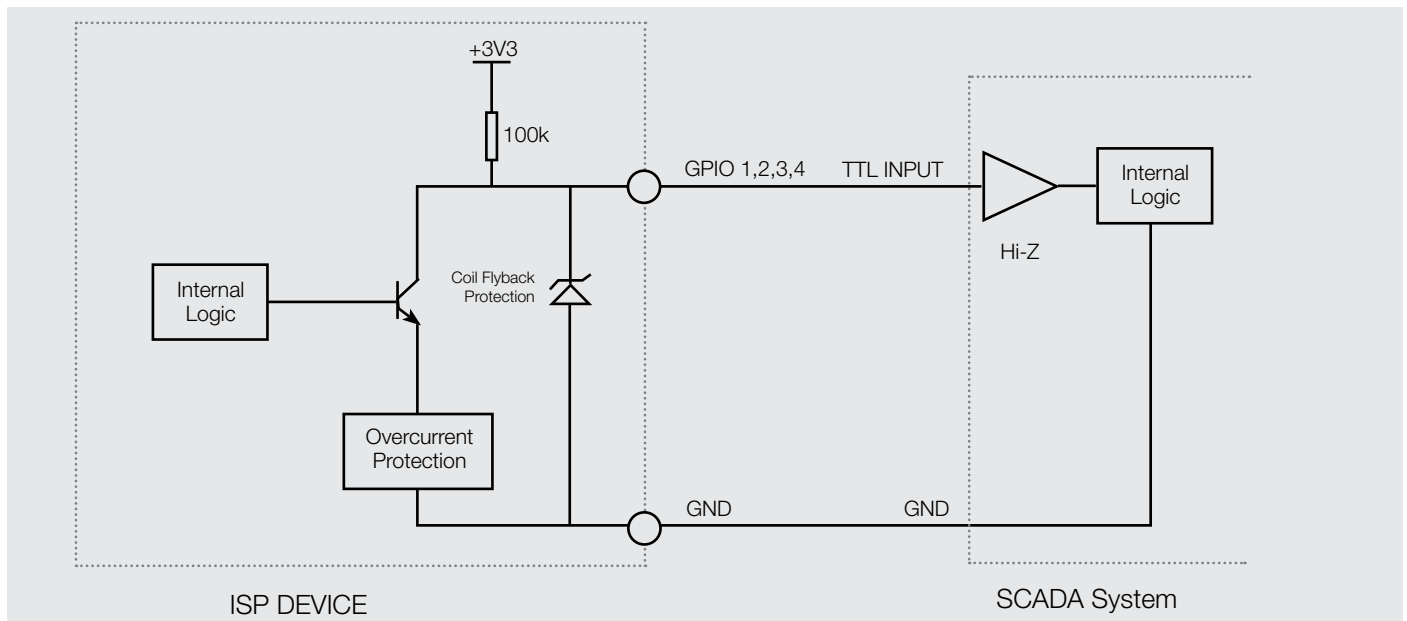

The GPIO's number, it's required function and its' active high or low signaling states are configured in webpage.

INSTALLATION & SETUP (CONT.)

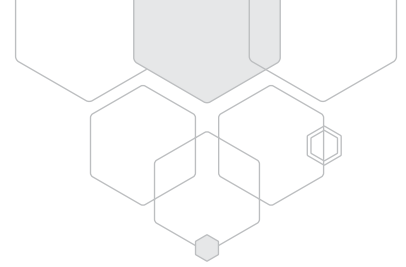

NETWORK CONFIGURATION

DYNAMIC IP (RECOMMENDED)

The amplifier ships with DHCP client mode enabled by default. This means you can connect your device to a LAN (network) that has DHCP enabled and an IP address will automatically be allocated for the amplifier. To do this, simply plug the ethernet cable into the rear of the amplifier to the port labelled “Ethernet” and connect the other end to a router/switch.

Once placed on a DHCP network the amplifier can be accessed via a web browser with the address listed below.

STATIC IP

If a point to point connection is required between the PC and amplifier then a static IP address can be setup in the PC operating system to connect to the default static IP address of the amplifier:

Default Static IP: 192.168.1.10

Default Static IP Subnet: 255.255.255.0

NETWORK ACCESS

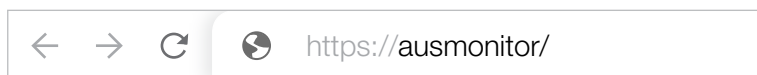

Windows Machine (and any OS that has a NetBIOS client installed and operational):

Supported Browsers: Google Chrome, Firefox

LAN address (via NetBIOS): <http://ausmonitor/>

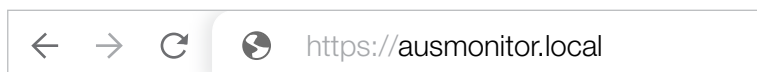

OSX (and any OS that has Bonjour installed and operating):

Supported Browsers: Google Chrome, Safari, Firefox

LAN address (via Bonjour (mDNS)): <http://ausmonitor.local>

INSTALLATION & SETUP (CONT.)

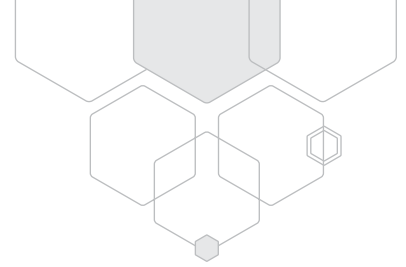

RESET BUTTON

The reset button is used to reset the amplifier back to various factory settings. The following sequences reset the amplifier settings back to the default states:

RESET NETWORK CONFIGURATION TO FACTORY DEFAULT:

Hold down the reset button for approx 5 seconds until the amber, red and green LEDs all flash on once. Immediately release the button.

The network configuration will all be restored to factory defaults listed below:

DHCP Mode = True

DHCP Default IP = 192.168.1.10

NetBIOS Name = http://ausmonitor/

Bonjour (Multicast DNS) = http://ausmonitor.local

RESET ADMIN ACCOUNT LOGIN SETTINGS TO FACTORY DEFAULT:

Hold down the reset button for approx 10 seconds until the amber, red and green LEDs all flash on twice. Immediately release the button.

The account login settings will all be restored to factory defaults listed below:

Username: admin

Password: admin

RESET BUTTON HELD DOWN FOR 15 SECONDS (RESET ALL SETTINGS TO FACTORY DEFAULT):

CAUTION: You should export the device configurations from the webpage before issuing this command so that all current user data such as accounts and audio settings can be exported to a file then re-imported once the factory default is issued. This will avoid a frustrating loss of user settings.

Hold down the reset button for approx 15 seconds until the amber, red and green LEDs all flash on three times. Immediately release the button.

The network configuration, user account data and audio settings will be set back to the factory default values.

INSTALLATION & SETUP (CONT.)

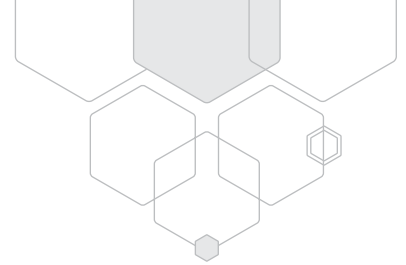

EXPANSION BOARD INSTALLATION

The following instructions are used to install the following supported expansion boards:

- DM4x4 Dante Expansion Board (4 Inputs/ 4 Outputs)
- AM4 Analogue Expansion Board (4 Line level inputs)

INSTALLATION INSTRUCTIONS:

 **IMPORTANT:** Ensure the power is removed from the amplifier before adding or removing an expansion card. Hot plugging expansion board may result in failure of the amplifier or expansion card

1. Remove the blanking plate from the rear of the amplifier by unscrewing the 2 Philips head screws securing the plate (see image below):



2. Remove the blanking plate from the ribbon cable by untying the twist tie (see image below):



3. Install the ribbon cable into the expansion board firmly into the correct position (see example image below):



4. Push the card back in the unit and install the 2 outermost Philips head screws from the supplied blanking plate (see image below):

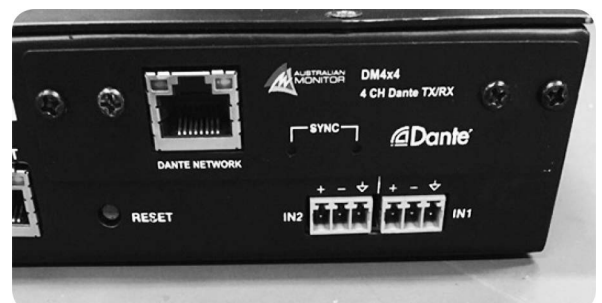

INSTALLATION & SETUP (CONT.)

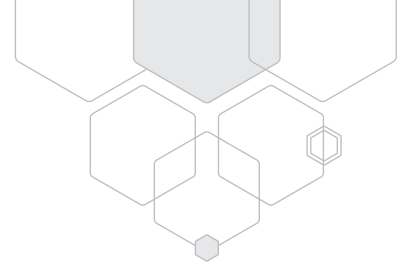

POWER REQUIREMENTS

Power consumption for your model of the ISP series amplifier is indicated on the rear panel for 1/8th output power. Ensure that your mains voltage is the same as the rear panel mains voltage marker ($\pm 10\%$).

MOUNTING

The ISP series amplifiers are one or two rack units high (1U) (2U) and will fit a standard EIA 19" or rack.

Typically amplifiers may be stacked directly on top of each other with no need for spacing between units, unless installed in high ambient temperature environments where a single rack unit space between amplifiers will assist cooling further.

COOLING

The IS2120P, IS2250P, IS4120P and IS4250P amplifiers are cooled by axial fans which draw air inside the amplifier and expel the heated air outside the amplifier. These amplifiers offer variable speed fans which run at half speed up to full speed when the internal heatsink temperature increases.

An unrestricted airflow into and out from the amplifier must be provided. Any restriction of the air flow will cause heat to build up within the unit and possibly force the unit into its thermal shutdown mode.

If the amplifiers are to be operated in an environment where the airflow is restricted such as sealed racks, cooling should be supplemented by extra cooling fans to evacuate the heated air and aid the flow of cool air through the unit.

BALANCED INPUT WIRING

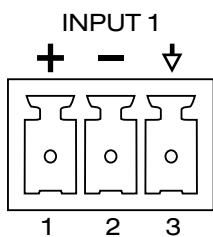

IMPORTANT: Do not directly connect pin 3 on the amplifier's input to the amplifier's chassis, speaker ground or power ground!



WARNING: Input signal ground is not to be used as a safety ground (earth).

The balanced input to the amplifier is 3-pin configuration and requires all three pins to be connected. Only high quality twin-core shielded cable should be used.

Pin 1 is the left most pin when viewed from the back of product.

Pin 1 = Hot (non-inverting or in phase)

Pin 2 = Cold (inverting or reverse phase)

Pin 3 = Signal Ground

When wiring from an unbalanced source you must ensure that pin 2 is connected to pin 3 (Signal Ground), either by linking the pins in the input connector or by the source equipment's output wiring.

When wiring for an unbalanced source:

Pin 1 = Hot (non-inverting or in phase)

Pin 2 = Signal Ground

Pin 3 = Signal Ground

INSTALLATION & SETUP (CONT.)

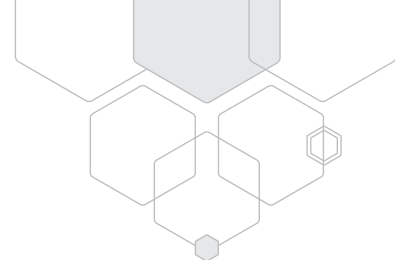

OUTPUT WIRING

When wiring up your speakers always use the largest gauge wire your connector will accept. The longer the speaker lead the greater the losses which will result in reduced power and less damping at the load. We recommend using a heavy duty, two core flex (four core flex if bi-amping) 10 to 12 gauge (2mm² to 2.5mm² or 50/0.25 or equivalent) as a minimum.

SPEAKER OUTPUTS

The amplifier output has a 6 pin output screw terminal with a pre-fitted link between the 4Ω and the high impedance output.

- 70V
- Fit the link between 4Ω and the OT-IN. (This connects the amplifier output to the input of the 70/100V transformer)
 - Connect your speaker to the HIGH IMPEDANCE OUTPUT 'C' and '70V' connections
- 100V
- Fit the link between 4Ω and the OT-IN. (This connects the amplifier output to the input of the 70/100V transformer)
 - Connect your speaker to the HIGH IMPEDANCE OUTPUT 'C' and '100V' connections
- 4Ω or 8Ω operation
- Remove the link between 4Ω and the OT-IN
 - Connect your speaker to the LOW IMPEDANCE OUTPUT 'C' and '4Ω' connections

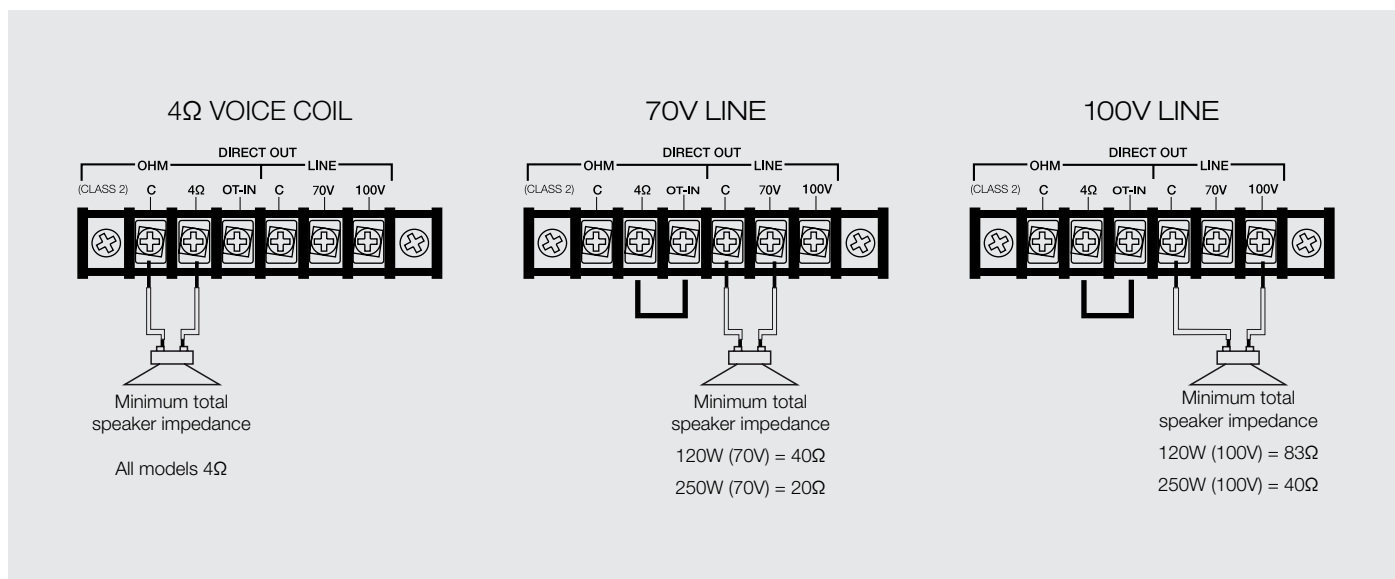

BASIC SETUP & OPERATION

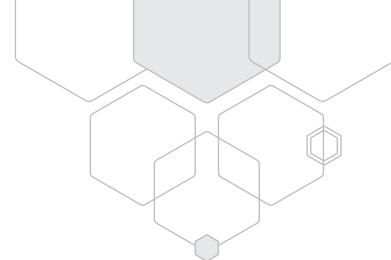

FAULT FINDING

STATUS INDICATOR

If the blue STATUS LED is flashing instead of remaining on then a specific system state is being displayed. See the table below on the meaning and of the system state.

The Status LED should indicate the following:

LED	MEANING	INDICATION
Blue On	Normal Operation	LED solid on. Indicates that device is powered and that no faults exist.
Blue Slow Flash	Standby Mode	Flash LED: On for 50ms, Off for 4s
Blue Flash	Error Mode	LED Off for 2s followed by a flash count of the error code, On for 300ms, Off for 300ms. Multiple errors will be indicated in consecutive error sequences. Refer to table below for list of error codes.

The list of error codes is:

ERROR CODE	STATUS LED ERROR FLASH COUNT
Configuration failure	1
Nor Flash image failure	2
Nor Flash read/write/erase failure	3
Power Amplifier initialisation failure	4
DSP failure	5
Bootloader failure	6
File System failure	7
Expansion initialisation failure	8
ADC initialisation failure	9

PROTECT INDICATOR

The following table indicates the meaning of each protection mode

LED	MEANING	RESOLUTION
Yellow flashing	Amplifier temperature warm	None required
Yellow on	Amplifier temperature hot	None required
Red flashing	Amplifier over temperature*	The amplifier has shutdown. It will automatically restart once it has cooled down
Red on	Amplifier protect	Check the speakers connected to the amplifier are correctly wired. Power cycle the unit and retry.

* In the advent of a thermal overload, the internal operating temperature of the amplifier has exceeded a safe level of operation. The fan will continue to run and once the amplifier has cooled it will return to normal operation.

SIGNAL INDICATOR

The following table indicates the meaning of each signal mode

LED	MEANING	RESOLUTION
Green on	Audio signal present	None required
Green off	No audio signal present	Increase the input audio level
Green flashing	Amplifier channel is set to mute	Unmute the channel using the Web application

WEBSITE USER INTERFACE

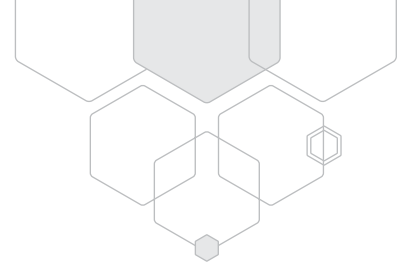

LOGIN

- 1) Navigate to the amplifier in a supported web browser using `http://ausmonitor/` (Windows) or `http://ausmonitor.local` (Mac OSX, Linux)
- 2) You will be presented with the amplifier login page. The default login is:
Username: admin
Password: admin

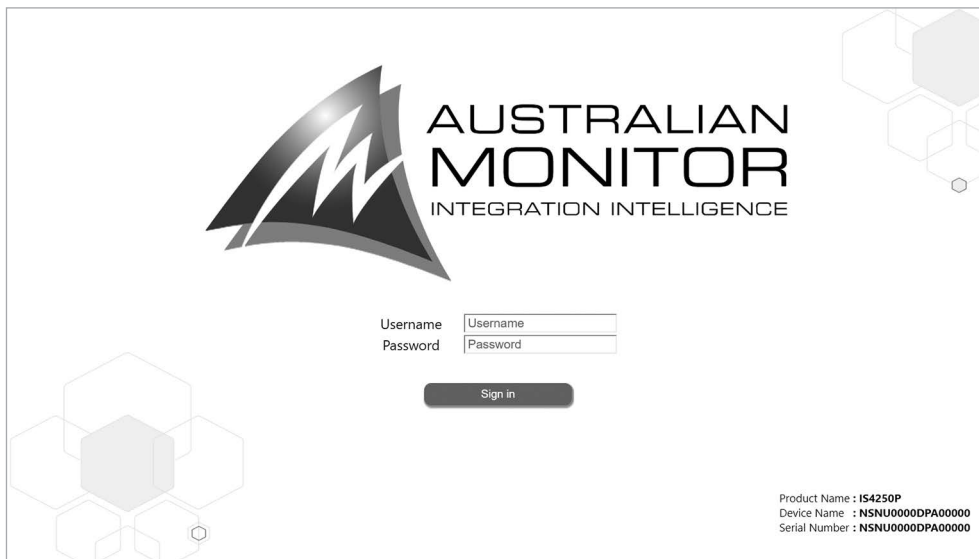

TABS

There are 6 main tabs hosted by the web server that are your used to control the amplifier:



HOME TAB:

This is the main dashboard display for the amplifier. Each channel output level is displayed with a fader to control the output volume. The status of each channel is also displayed at the very bottom.

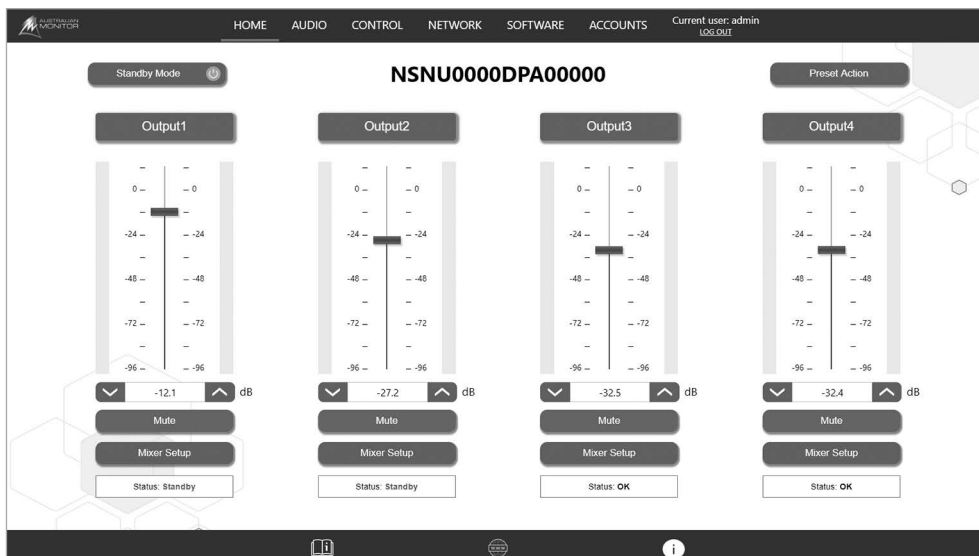

WEBSITE USER INTERFACE (CONT.)

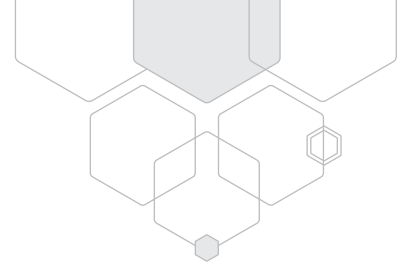

AUDIO TAB:

The audio setup page is used to display the signal path of the amplifier and the DSP functional blocks that are enabled. If the block is grey then the DSP functional block is disabled and considered a bypass. If the DSP functional block is green then it is enabled.

The mixer functional block is always enabled by default and the default configuration is that each of the channel inputs maps to the same channel output with all other input sources muted.

To enable a DSP functional block. Click on the functional block and modify the parameters to suit and then make sure it is enabled.

Presets can also be saved and recalled for a given configuration and are accessed by the Preset Action button.

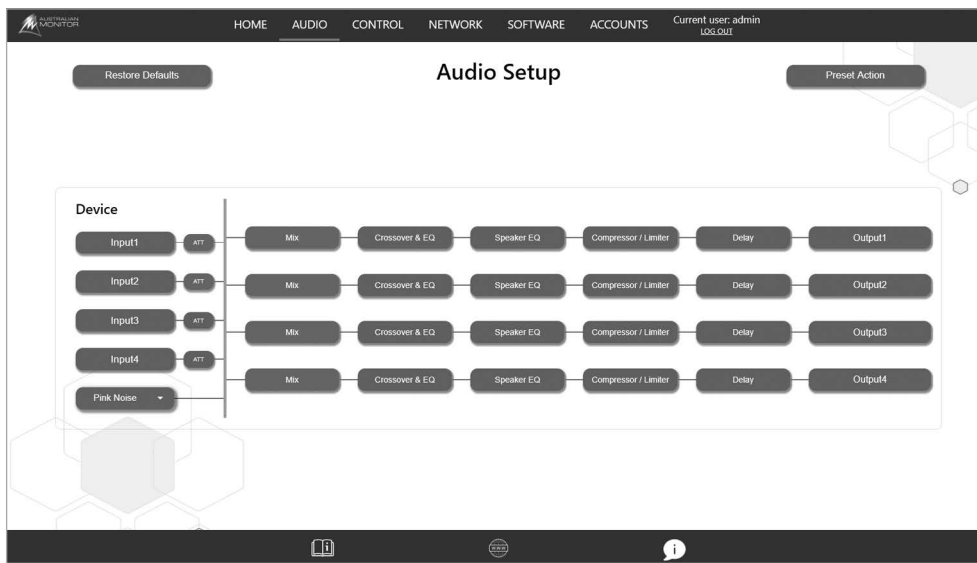

CONTROL TAB:

The control tab is used to restore default settings, configure auto standby and setup the GPIO control functionality. See standby and GPIO setup section of the manual for further details.

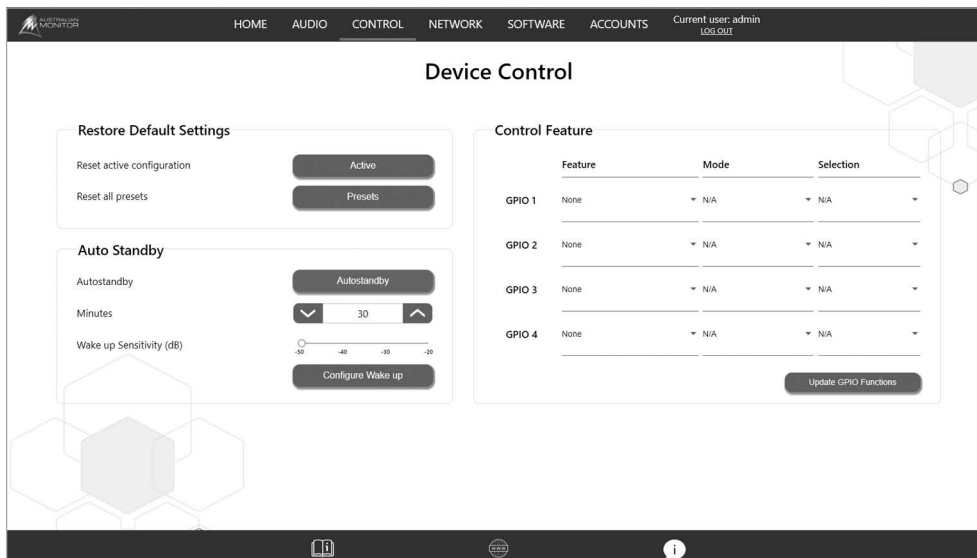

WEBSITE USER INTERFACE (CONT.)

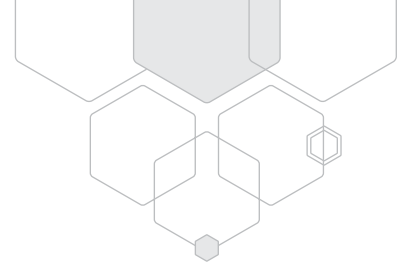

NETWORK SETTINGS TAB:

The network tab allows the network settings such as the domain name and IP address properties to be modified.

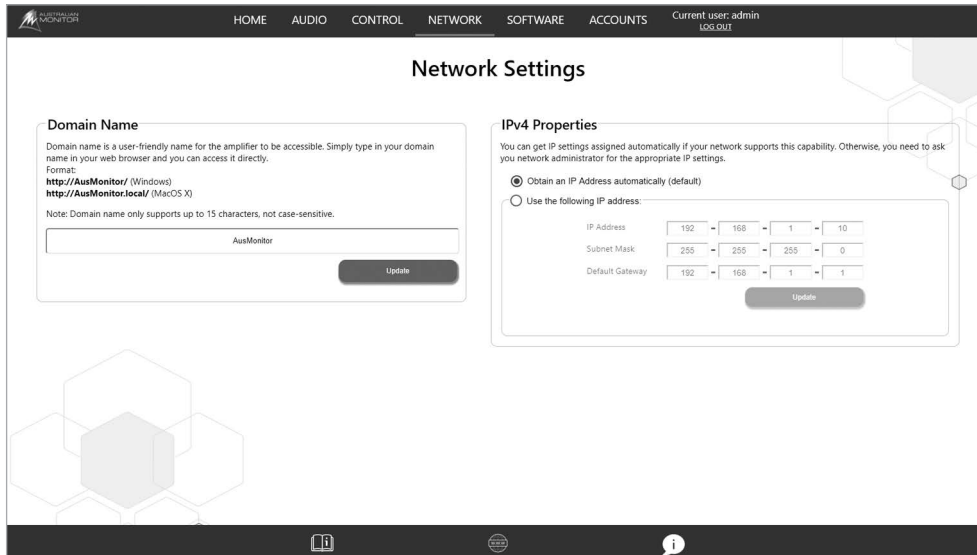

SOFTWARE TAB:

The software tab is used to manage the stored user settings and software versions.

If the amplifier is to be reset to a factory default state then the user must export the device configurations to a local machine. This will allow all of the custom settings of the amplifier to be saved to a local file on the PC. This file can be re imported back to the amplifier at any point in time.

When performing a software update its important not to interrupt the power to the amplifier during the update procedure. The update time can vary depending on the host machine but generally takes about 4 minutes to complete. The software updates the webpage and firmware in the amplifier concurrently.

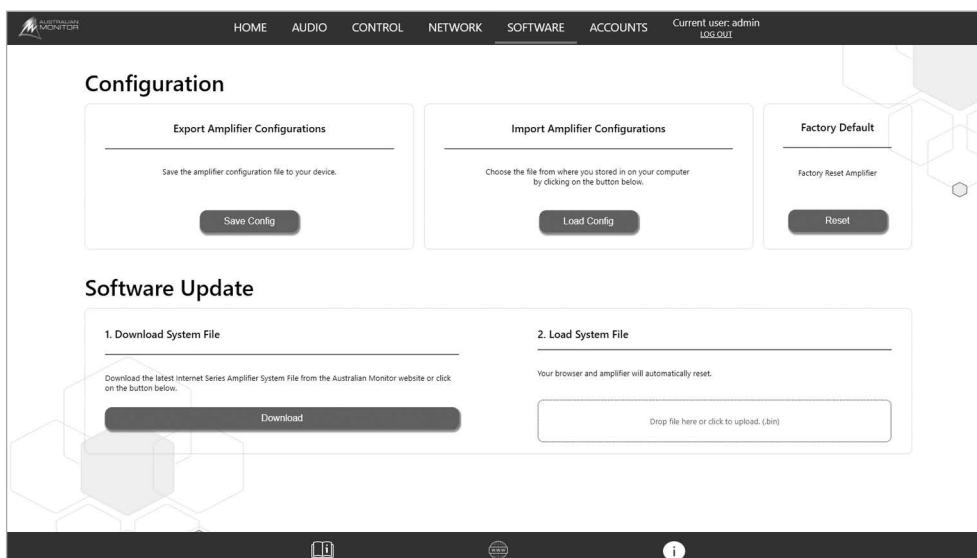

WEBSITE USER INTERFACE (CONT.)

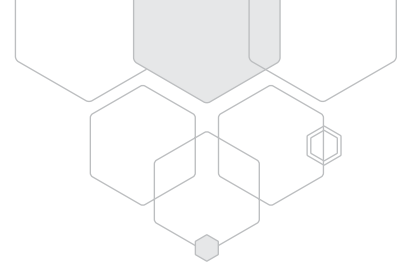

ACCOUNTS TAB:

The accounts tab allows up to 10 users to be created that can access the amplifier. The users can be standard users or administrative users.

Administrative users have full access to the following tabs:

- HOME
- AUDIO
- CONTROL
- NETWORK
- SOFTWARE
- ACCOUNTS

Standard users have access to the following tabs:

- HOME
- AUDIO

Accounts can also be made active/inactive so that the account information credentials are retained.

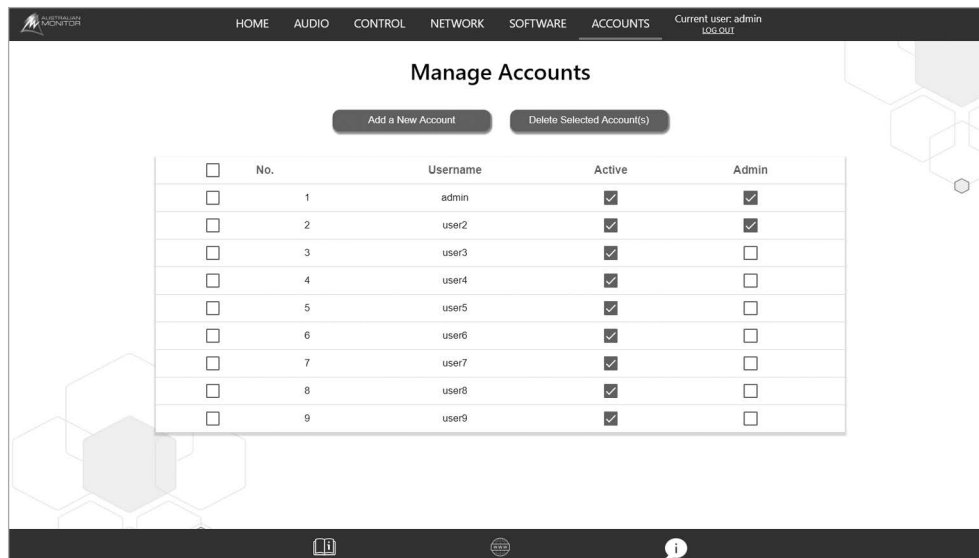

FOOTER TAB:

The footer tabs have provide the following functions:

- Download the latest owners manual from Australian Monitor website (this document)
- Link to the Australian Monitor website (<https://www.australianmonitor.com.au/>)
- Product information. This provides all of the installed software and hardware versions. The serial numbers are also recorded here.



MAINTENANCE FIRE REGULATION COMPLIANCE

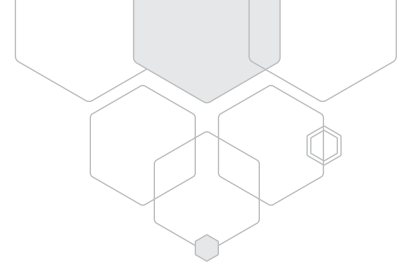

MAINTENANCE

Only competent or qualified persons should attempt any service or maintenance of your amplifier. Your ISP amplifier will need minimal maintenance. No internal adjustments need to be made to the unit to maintain optimum performance. To provide years of unhindered operation we suggest a maintenance inspection be carried out on annually.

FIRE REGULATION COMPLIANCE

This amplifier is not certified to fire regulations standards such as EN 54-16

SPECIFICATIONS

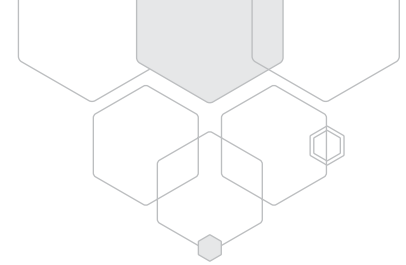

	IS2120P	IS2250P	IS4120P	IS4250P	CONDITIONS/COMMENTS
TOPOLOGY	Class-D				
CHANNELS	2		4		
POWER OUTPUT (PER CH) 4Ω 70V 100V	136W 130W 128W	262W 244W 221W	140W 132W 138W	261W 245W 223W	1kHz. 1%THD. -10W/+30W, CEA-2006, one channel driven
MAXIMUM OUTPUT LEVEL (DBV/VRMS)	27.2dBV/ 23.3Vrms	30.0dBV/ 32.6Vrms	27.2dBV/ 23.3Vrms	30.0dBV/ 32.6Vrms	20Hz~20kHz, <1%THD, 4Ω
SYSTEM GAIN	27.2dB	30.0dB	27.2dB	30.0dB	
FREQUENCY RESPONSE 4Ω 70V 100V	20 ~ 20kHz 75 ~ 16kHz 75 ~ 16kHz				3dB below clipping, +0/-3dB.±5Hz 3dB below clipping, +0/-3dB.±5Hz Low Frequency ±2kHz High Frequency 3dB below clipping, +0/-3dB.±5Hz Low Frequency ±2kHz High Frequency
SIGNAL TO NOISE RATIO	100 dB				Max Output, 1kHz, 20kHz BW, A-Weighted
THD+N. 4Ω. 1kHz	< 0.05%	< 0.02%	< 0.04%	< 0.02%	3dB below clipping, 1kHz. 20kHz BW, Unity Gain, A-Weighted
THD+N. 4Ω. 20Hz ~ 20kHz	< 0.05%	< 0.03%	< 0.05%	< 0.03%	3dB below clipping, 20Hz ~ 20kHz. 20kHz BW, Unity Gain, A-Weighted
THD+N. 70V. 1kHz	< 0.07%	< 0.03%	< 0.06%	< 0.03%	3dB below clipping, 1kHz. 16kHz BW, Unity Gain, A-Weighted
THD+N. 70V. 80Hz ~ 16kHz	< 0.12%	< 0.05%	< 0.1%	< 0.05%	3dB below clipping, 100Hz ~ 16kHz. 16kHz BW, Unity Gain
THD+N. 100V. 1kHz	< 0.08%	< 0.03%	< 0.08%	< 0.03%	3dB below clipping, 1kHz. 16kHz BW, Unity Gain, A-Weighted
THD+N. 100V. 80Hz ~ 16kHz	< 0.17%	< 0.05%	< 0.15%	< 0.05%	3dB below clipping, 100Hz ~ 16kHz. 16kHz BW, Unity Gain
INTERMODULATION DISTORTION - SMPTE. 4Ω	<0.02%				60Hz/7kHz, 4:1, 3dB below clipping
INTERMODULATION DISTORTION - ITU-R (CCIF). 4Ω	<0.01%				19kHz/20kHz, 1:1, 3dB below clipping
DAMPING FACTOR 4Ω	>30	>40	>30	>40	20Hz ~ 1kHz
DC OUTPUT OFFSET	<1mV				
CHANNEL SEPARATION (CH-TO-CH) 4Ω	-75dB				Max Output, one channel driven 20Hz ~ 1kHz 1kHz ~ 20kHz
CHANNEL SEPARATION (CH-TO-CH) 70V/100V	-75dB -65dB				Max Output, one channel driven 50Hz ~ 1kHz 1kHz ~ 16kHz
INPUT/OUTPUTS					
AUDIO INPUT	Balanced Phoenix Input per channel				
DATA/CONTROL	Ethernet (100BASE-T) Logic (STANDBY, GPIO1, GPIO2, GPIO3, GPIO4, GND). 6 pin 3.81mm Euroblock connector. Expansion Slot				
SPEAKER OUTPUT	6 pin Screw Terminal per channel				
SENSITIVITY					
AUDIO INPUT SENSITIVITY	1V RMS				1V RMS = Full Power Output
AUDIO INPUT MAX LEVEL	+17.5 dBu (6.1Vrms)				Pad -15dB

SPECIFICATIONS CONT.

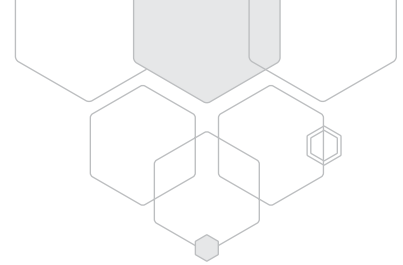

	IS2120P	IS2250P	IS4120P	IS4250P	CONDITIONS/COMMENTS
DSP					
	Volume control Matrix Mixer High/Low/All pass filters 12 band parametric equaliser per channel Compressor/Limiter Delay up to 75m(220ms) per amplifier output Audio level sense for standby/auto-wake Internal Sine Wave Generator (500, 1k, 5k and 10kHz) Internal Pink Noise Generator				
MISCELLANEOUS					
INPUT IMPEDANCE	10k Ω				\pm 10% Balanced.
INPUT CMRR	>50dB				20Hz ~ 20kHz
INPUT SIGNAL DETECTION THRESHOLD	400uVrms (-66dBu)				
WAKE UP TIME FROM STANDBY	724	650	724	650	ms
LED STATUS	4 level meter, Protect, Status				
OVERLOAD PROTECTION	Temperature, Over Voltage, Current Limit				
POWER REQUIREMENTS					
AC INPUT	100-240VAC, 50-60Hz				\pm 10%
AC POWER FACTOR	>0.97		>0.96	>0.95	Max Output, 1kHz, 230VAC
AC INPUT CONNECTOR	IEC 60320-C14				
AC MAINS FUSE	T5AL 250V	T6.3AL 250V	T6.3AL 250V	T8AL 250V	
MAXIMUM INRUSH CURRENT	70A	70A	70A	70A	230VAC, 50Hz
RMS CURRENT DRAW					
STANDBY	0.1	0.115	0.1	0.1	230VAC, 50Hz, 100V Output, 1kHz, Sine
IDLE	0.185	0.19	0.227	0.29	
1/8TH POWER	0.346	0.558	0.575	1.09	
1/3RD POWER	0.626	1.2	1.16	2.39	
FULL POWER	1.635	2.65	2.58	3.9	
POWER CONSUMPTION					
STANDBY	2W	1W	2W	2W	230VAC, 50Hz, 100V Output, 1kHz Sine 230VAC, 50Hz, 100V Output, 1kHz Sine 230VAC, 50Hz, 100V Output, 1kHz Sine 230VAC, 50Hz, 100V Output, 1kHz Sine 230VAC, 50Hz, 100V Output, 1kHz Sine IS2120P = 2 x 120W, IS2250P = 2 x 200W, IS4120P = 4 x 100W, IS4250P = 4 x 140W
IDLE	17W	23W	32W	37W	
1/8TH POWER	64W	115W	120W	215W	
1/3RD POWER	133W	262W	253W	512W	
FULL POWER	368W	595W	582W	865W	
EFFICIENCY					
1/8TH POWER	65%	68%	68%	70%	230VAC, 50Hz, 100V Output 230VAC, 50Hz, 100V Output 230VAC, 50Hz, 100V Output IS2120P = 2 x 120W, IS2250P = 2 x 200W, IS4120P = 4 x 100W, IS4250P = 4 x 140W
1/3RD POWER	69%	70%	72%	70%	
FULL POWER	68%	67%	65%	72%	
THERMAL DISSIPATION					
STANDBY	5	5	5	5	Excludes Load Power (1W = 3.412BTU/Hr)
IDLE	59	77	107	126	
1/8TH POWER	187	330	349	609	
1/3RD POWER	374	727	703	1414	
FULL POWER	437	720	757	904	

SPECIFICATIONS CONT.

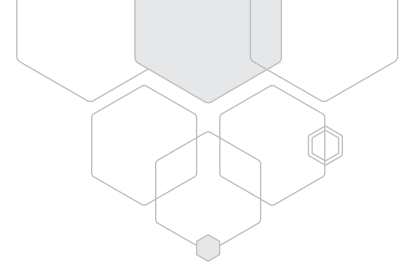

	IS2120P	IS2250P	IS4120P	IS4250P	CONDITIONS/COMMENTS
PRODUCT DIMENSIONS (WITH RACK EARS)	483mm x 325mm x 44.5mm (19.0"W x 12.8"D x 1.75"H)		483mm x 389mm x 89mm (19.0"W x 15.32"D x 3.5"H)		
PRODUCT DIMENSIONS (WITHOUT RACK EARS)	435mm x 325mm x 44.5mm (17.13"W x 12.8"D x 1.75"H)		435mm x 389mm x 89mm (17.13"W x 15.32"D x 3.5"H)		
SHIPPING DIMENSIONS	525mm x 425mm x 120mm (20.7"W x 16.7"D x 4.7"H)		546mm x 491mm x 197mm (21.5"W x 19.3"D x 7.8"H)		
NET WEIGHT	7.2 Kg (15.9 lbs)	9.0 Kg (19.9 lbs)	14.0 Kg (30.9 lbs)	16.0 Kg (35.3 lbs)	
SHIPPING WEIGHT	9.8 Kg (21.7 lbs)	11.2 Kg (24.7 lbs)	15.6Kg (34.5 lbs)	18.6Kg (41.1 lbs)	
MOUNTING	1 RU		2RU		
OPERATING TEMPERATURE	0°C to 40°C (95% RH)				
COOLING SYSTEM	Axial Fans				
FAN NOISE	60dBA				Noise measured at 20cm from fan intake
FINISH	Satin				
COLOUR	Black				
ACCESSORIES	DM4x4 Dante® Expansion Board, AM4 Analogue Expansion Board				
APPROVALS	CE, IEC, RCM				
SUPPORTED OPERATING SYSTEMS	Windows, OSX & Linux, Android & iOS				

Due to continuous improvements, all specifications are subject to change



ENGINEERED BY AUSTRALIAN MONITOR

Address: 1 Clyde St, Silverwater NSW 2128 Australia.

Website: www.australianmonitor.com.au

International enquiries email: international@australianmonitor.com.au

ABN 35 007 573 417